

SERVICE



MANUAL

CONTENTS

X-RAY RADIATION PRECAUTION.....	1
SAFETY PRECAUTION.....	1
PRODUCT SAFETY NOTICE.....	2
GENERAL INSTRUCTION.....	2
ALIGNMENT ITEMS AND PROCEDURE.....	2
FACTORY ADJUSTMENT MODE.....	4
ADJUSTMENT METHOD.....	4
CHECKING POINTS.....	6
OUT-FACTORY MODE PRESET.....	7
POWER ADAPTABILITY CHECK.....	7
USA CHANNEL FREQUENCY TABLE (181 CH).....	16
WIRING DIAGRAM.....	18
BLOCK DIAGRAM.....	19
IC BLOCK DIAGRAM.....	20
SCHEMATIC DIAGRAM.....	28
ELECTRICAL PARTS LIST.....	30

CAUTION: THIS SERVICE MANUAL IS ONLY FOR PROFESSIONAL SERVICE PERSONNEL'S REFERENCE. BEFORE SERVICING THIS CHASSIS, PLEASE READ THE FOLLOWING NOTICE ITEMS.

1. SAFETY INSTRUCTION AND GENERAL INSTRUCTION

Before servicing and aligning this equipment, please read the following “**X-RAY RADIATION PRECAUTION**”, “**SAFETY PRECAUTION**” and “**PRODUCT SAFETY NOTICE**”.

1.1 X-RAY RADIATION PRECAUTION

- 1) Excessive high voltage can produce potentially hazardous X-RAY RADIATION. To avoid such hazards, the high voltage must not be above the specified limit. The normal value of the high voltage of the set should be within 33kV at zero beam current (minimum brightness) under DC145V main power (B+), the high voltage must not, under any circumstances, exceed 35 kV.
 - 2) Each time a set requires servicing, the high voltage should be checked following the HIGH VOLTAGE CHECK procedure. It is recommended the reading of the high voltage be recorded as a part of service record. It is important to use an accurate and reliable high voltage meter.
- * When checking, main power (B+) should be kept at 145 V (for Toshiba pure flat CRT).
- 3) The primary source of X-RAY RADIATION in this TV receiver is the picture tube. For continuous X-RAY RADIATION protection, the replacement tube must be exactly the same type tube as specified in the parts list.
 - 4) Some parts in this receiver have special safety-related characteristics for X-RAY RADIATION protection. For continuous safety, parts replacement should be undertaken only after referring to the PRODUCT SAFETY NOTICE below.

1.2 SAFETY PRECAUTION

WARNING:

Service should not be attempted by anyone unfamiliar with the necessary precaution on this receiver. The following are the necessary precautions to be observed before servicing this chassis.

- 1) Since the power supply circuit of this receiver is directly connected to the AC power line, an isolation transformer should be used during any dynamic service to avoid possible shock hazard.
- 2) Always discharge the picture tube anode to the CRT conductive coating before handling the picture tube. The picture tube is highly evacuated and if broken, glass fragments will be violently expelled. Use shatter proof goggles and keep picture tube away from the unprotected body while handling.
- 3) When replacing a chassis in the cabinet, always be certain that all the protective devices are put back in place, such as: non-metallic control knobs, insulating covers, shields, isolation resistor-capacitor network etc.
- 4) When replacing parts or circuit boards, disconnect the power cord.
- 5) When replacing a high wattage resistor (oxide metal film resistor) on the circuit board, keep the resistor 10mm (1/2in) away from circuit board.
- 6) Connection wires must be kept away from components with high voltage or high temperature.

7) If any fuse in this TV receiver is blown, replace it with the FUSE specified in the chassis parts list.

1.3 PRODUCT SAFETY NOTICE

Many electrical and mechanical parts in the chassis have special safety-related characteristics. These characteristics are often passed unnoticed by a visual inspection and the X-RAY RADIATION protection afforded by them cannot necessarily be obtained by using replacement components rated for higher wattage, etc. Replacement parts which have these special safety characteristics are identified in this manual and its supplement electrical components having such features are shaded on the schematic diagram and the parts list.

Before replacing any of these components, read the parts list in this manual carefully. The use of substitute replacement parts which do not have the same characteristics as specified in the parts list may create shock, fire, X-RAY RADIATION or other hazards.

1.4 General instruction

1.4.1 This chassis' EEPROM(N801 M24C08) should copy standard data first, if necessary, deal it with "factory adjustment". If directly use blank EEPROM, should first preset I²C data, then go on other common alignment. For factory adjustment method, refer to **The appendix: Factory adjustment mode.**

1.4.2 If without special indication, the alignment is conducted on the below condition:

- a) AC power supply 120 V/60 Hz. (North America area) or others (depending on selling market).
- b) The whole unit is preheated for more than 30 min.

1.4.3 There is built-in auto degaussing circuit, it will degauss automatically within 1second after turning on. And the auto degaussing circuit can effect only when turning off the set and waiting for at least 30min and then turning on.

1.4.4 If CRT is with magnetism and affects color purity and convergence, the internal degaussing can not degauss completely, can use degaussor to degauss externally. If color purity and convergence is still poor, then do color purity and convergence adjustment.

2 Alignment items and procedure

- 2.1 B+ voltage check
- 2.2 OSD character center adjustment
- 2.3 RFAGC voltage adjustment
- 2.4 Focus adjustment
- 2.5 Screen-grid voltage and white balance adjustment
- 2.6 SECAM colour adjustment
- 2.7 Horizontal, vertical scanning center adjustment
- 2.8 Horizontal, vertical scanning amplitude adjustment
- 2.9 Raster correction adjustment
- 2.10 The alignment flow chart see below figure.

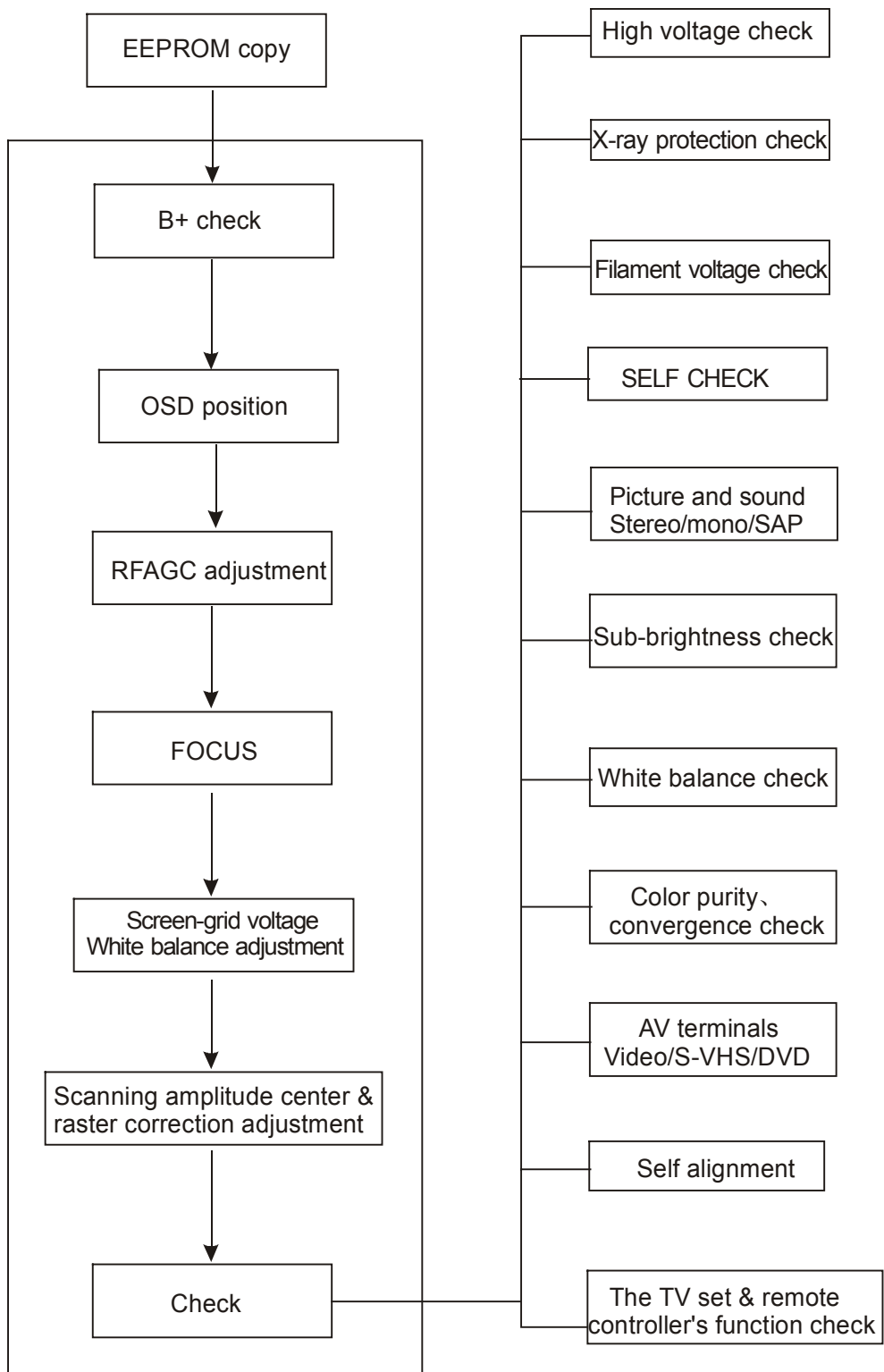

Figure 1: Alignment flow chart

3 Factory adjustment mode

3.1 Enter into factory adjustment menu

Press SLEEP→PIC→DSP→MENU button on the remote controller in order (the period of two press should be less than 5 seconds), the screen will appear factory alignment menu.

3.2 Factory menu operation

Repeatedly press "MENU" button, then the menu will enter into PAGE 1→PAGE 2→PAGE 3→PAGE 4→PAGE 5 and recycle; press ▲ or ▼ button can select adjustment items upward or downward, and press ◀ or ▶ button to confirm or adjust the item's value.

3.3 To exit the factory menu

Press "SLEEP" button to exit the factory adjustment menu.

4 Adjustment method

4.1 B+ voltage adjustment

- a) Make sure the power supply is AC120 V/60 Hz (for America or Canada area).
- b) Connect the digital voltmeter to B+ testing point, receive A7 signal, set the picture control to "NATURAL" status, adjust RP501 to make B+ voltage be $145\text{ V}\pm 0.3\text{ V}$ (just for TOSHIBA pure flat CRT, as regards to other CRT, B+ value will be marked on the parts list.)
- c) In STAND BY mode, the B+ voltage will be about 84 V.

4.2 OSD position adjustment

Receive NTSC signal, change the factory adjustment menu page 3 OSD item's value to make user's menu be in screen's center position.

4.3 AGC adjustment

- a) Receive 60 dB split field (or grey-scale) signal.
- b) Use oscilloscope or digital voltmeter to monitor tuner 1 pin's voltage (RFAGC pin) .
- c) Select factory adjustment menu page 4 R-AGC item, making use of [←][→] button to increase the value from down to up until the voltage just reach 4.0 V, at this time picture noisy spots should disappear basically. Otherwise continue to fine tune R-AGC item.
- d) Exit the factory menu.

4.4 Focus adjustment

4.4.1 Receive A12 signal, set picture mode to "MEMORY 2" status.

4.4.2 Adjust FBT FOCUS potentiometer to make screen's B area's focus optimum.

4.5 Screen-grid voltage, white balance adjustment

4.5.1 Receive A7 split field signal, set picture mode to "MEMORY 3" status.

4.5.2 Keep RCUT's value, not change it (for example set it to 60), roughly adjust GCUT and BCUT value to make white balance basically normal.

4.5.3 Set colour, contrast to minimum, set brightness to 50. Use oscilloscope to monitor CRT board red gun waveform, adjust PAGE 4 BRTS value to make black level be 180 V.

4.5.4 Adjust SCREEN (accelerating electrode) potentiometer to make picture brighten 4 lattices.

4.5.5 Fine adjust white balance (colour temperature: $12000\text{K}\pm 8\text{MPCD}$ $X=0.270\pm 0.008$)

Y=0.283±0.008).

4.5.6 Adjust PAGE 2 BRTN value to make colour , brightness, contrast all be minimum, picture“white block“slightly lights up.

4.6 Horizontal, vertical scanning center adjustment

4.6.1 PAL (50 Hz) horizontal、vertical center adjustment

Receive G23 signal, set picture mode to “MEMORY 2“status, fine tune vertical center VP50, horizontal center HPOS, to make picture center be in accordance with screen center.

4.6.2 NTSC (60 Hz) H-center, V-center adjustment

Receive A6 signal, set picture mode to “MEMORY 2“ status, adjust V-center VP60, H-center HPS, to make picture center be in accordance with screen center.

4.7 Vertical scanning amplitude adjustment

4.7.1 PAL (50 Hz) vertical amplitude adjustment

Receive D35 signal, set picture mode to “MEMORY 2“ status, adjust vertical amplitude HIT, to make picture up/down overscanning be screen size’s 8%.

4.7.2 NTSC (60 Hz) vertical amplitude adjustment

Receive A12 signal, set picture mode to “MEMORY 2“ status, adjust V-amplitude HITS, to make picture up/down overscanning be screen size’s 8%.

4.8 Raster correction adjustment、H-amplitude adjustment

4.8.1 PAL (50 Hz) raster correction adjustment , H-amplitude adjustment.

Receive PAL white crosshatch signal, set picture mode to “MEMORY 2“ status, adjust DPC to make raster distortion be in minimum, adjust WID to make picture left/right overscanning be screen size’s 8%.

4.8.2 NTSC (60 Hz) raster correction adjustment

Receive NTSC A21 signal, set picture mode to “MEMORY 2“ status, adjust DPCS to make raster distortion minimum, adjust WIDS to make picture left/right overscanning be screen size’s 8%.

4.9 If scanning linearity distortion and raster geometrical distortion can not reach the requirements, and if necessary, can make use of factory adjustment menu to adjust the following items:

VLIN	V-linearity adjustment (PAL)
VLIS	V-linearity adjustment (NTSC)
VSC	Vertical S-correction adjustment (PAL)
VSS	Vertical S-correction adjustment (NTSC)
CNRT	Top corners’ correction
CNRB	Bottom corners’ correction
KEY	Trapezoid correction (PAL)
KEYS	Trapezoid correction (NTSC)

4.10 Maximum sound output power

Receive single tone signal, set volume to maximum, the sound output power is 2×8 W. (can fine adjust factory menu V100).

5 Checking points

5.1 High voltage check

- 5.1.1 Connect high voltmeter to CRT second anode and GND.
- 5.1.2 Receive A7 signal, set picture mode to "MEMORY 2" status, measure the high voltage value, the reading should be $30.0\text{ kV} \pm 1\text{ kV}$.
- 5.1.3 When setting brightness and contrast to minimum (zero beam current), measure the high voltage value, the reading should not exceed 32 kV.

5.2 CRT filament voltage check

Receive A7 signal, set picture mode to "NATURAL" status, use effective value voltmeter to measure CRT filament voltage, the reading should be $(6.3 \pm 0.3)V_{\text{rms}}$.

5.3 X-ray protection check

- 5.3.1 Receive A7 signal, set picture mode to "MEMORY 2" status.
- 5.3.2 Short S301, X-ray protection circuit should effect.

5.4 "Self-check"function check

Press "SELF-CHECK"button, the screen will display the following information:

		M
SELF	CHECK	
BUS	LINE:	OK
BUS	CONT:	OK
SYNC:		OK

"OK" means bus, SYNC status, etc are normal.

If display "SCL-GND", means SCL short to GND. ;

"SDA-GND" means SDA short to GND.

"SCL-SDA" means SCL short to SDA.

5.5 Picture and sound check

- 5.5.1 Receive standard TV signal.
- 5.5.2 Make use of picture control buttons to check colour, contrast, brightness, sharpness, tint's control function.
- 5.5.3 Make use of sound control buttons to check sound control function.

5.6 Sub-brightness check.

Receive A7 signal, set colour, contrast, brightness all to 0, picture left one lattice slightly lights up.

5.7 This set can produce 14 kinds of testing signals by itself. In factory menu when select some adjustment item, every press of AV button for one time, it will produce one testing signal.

5.8 Colour purity and convergence check (in normal way).

5.9 AV terminal input/output check

5.10 Other control buttons on the set/remote controller function check.

6 Out-factory mode preset

Press "SHOP OUT" button, out-factory status will be preset to:

6.1	Picture menu:	Colour	70
		Brightness	70
		Contrast	100
		Sharpness	50
		Tint	50
		Blue background	On
6.2	Volume preset to:	30	
6.3	Language menu:	ENGLISH	
6.4	Colour system :	AUTO	
6.5	NOISE REDUCE:	OFF	
6.6	TV mode:	Channel positionA2	
6.7	SVM:	MILD	
6.8	V-CHIP PASSWORD:	0000	
6.9	CHILD LOCK MENU		
	PASSWORD:	0000	
6.10	SOUND MODE:	MEMORY 1	
6.11	TV/CATV CHANNEL:	Both set to ADD	
6.12	CCD CHANNEL:	Set to C1	
6.13	V-OHIP:	Set all ratings and contents to IGNORE	
6.14	V-CHIP BLOCK ON/OFF:	Set to ON	

7 Power adaptability check

AC 120 V/60 Hz (for North America area. If have other special AC power supply requirements, then check with requirements).

Appendix1 factory adjustment menu

Item NO.	OSD character	Preset	Adjustment item	Analogue setting	Input signal	Adjustment method	Testing point
1	HPOS	0F	50Hz H-center	MEMORY 2	D35	To make picture horizontal center be in accordance with CRT center	Screen
2	WID	16	50Hz H-amplitude	MEMORY 2	D35	To make horizontal amplitude meet standard	Screen
3	VP50	06	50Hz V-center	MEMORY 2	D35	To make picture vertical center be in accordance with CRT center	Screen
4	VLIN	0E	50Hz V-linearity	MEMORY 2	D35	To make upper, lower crosshatch height be equal.	Screen
5	VSC	07	50Hz vertical S-correction	MEMORY 2	D35	To make upper, middle, lower crosshatch height be equal.	Screen
6	HIT	2B	50Hz V-amplitude	MEMORY 2	D35	To make Vertical amplitude meet standard	Screen

7	KEY	22	50Hz trapezoid correction	MEMORY 2	D35	To correct picture trapezoid	Screen
8	DPC	18	50Hz pincushion correction	MEMORY 2	D35	To correct picture E/W pincushion	Screen
9	CNRT	08	Top edge and corner correction	MEMORY 2	D35/A12	To correct top edge and corner vertical line	Screen
10	VEHT	05	Vertical high voltage compensation	MEMORY 2	D35/A12	fix	Screen
11	HPS	04	60Hz H-center	MEMORY 2	A12	To make picture horizontal center be in accordance with CRT center.	Screen
12	WIDS	FD	60Hz H-amplitude	MEMORY 2	A12	To make horizontal amplitude meet standard.	Screen
13	VP60	02	60Hz V-center	MEMORY 2	A12	To make picture vertical center be in accordance with CRT center.	Screen
14	VLIS	FF	60Hz V-linearity	MEMORY 2	A12	To make upper, lower crosshatch height be equal	Screen
15	VSS	FE	60Hz vertical S-correction	MEMORY 2	A12	To make upper, middle, lower crosshatch height be equal.	Screen
16	HITS	FD	60Hz V-amplitude	MEMORY 2	A12	To make vertical amplitude meet standard	Screen
17	KEYS	01	60Hz trapezoid correction	MEMORY 2	A12	To correct picture trapezoid	Screen
18	DPCS	FF	60Hz pincushion correction	MEMORY 2	A12	To correct picture E/W pincushion	Screen
19	CNRB	07	Bottom edge and corner correction	MEMORY 2	D35/A12	To correct bottom edge and corner vertical line	Screen
20	HEHT	02	Horizontal high voltage compensation	MEMORY 2	D35/A12	Fix	Screen
21	RCUT	60	Dark area white balance		Black/white signal or A7 signal	To make picture dark area to obtain standard "white colour"	Screen
22	GCUT	60					
23	BCUT	60					
24	GDRV	30	Bright area white balance	MEMORY 1	Black/white signal or A7 signal	To make picture bright area to obtain standard "white colour"	Screen
25	BDRV	30					
26	CNTX	4E	Contrast maximum value setting	MEMORY 1	Gray scale	Fix	Screen
27	CNTC	30	Contrast middle value setting	Contrast 50	Gray scale	Fix	Screen
28	CNTN	18	Contrast minimum value setting	Contrast 0 Colour 0 Brightness 50	Gray scale	Fix	Screen
29	BRTX	70	Brightness maximum value setting	Contrast 50 Brightness 100 Colour 0	A7 signal	Fix	Screen

30	BRTC	50	Brightness middle value setting	Contrast 0 Brightness 50 Colour 0	A7 signal	Fix	Screen
31	BRTN	2C	Brightness minimum value setting	Contrast 0 Brightness 0 Colour 0	A7 signal	Refer to adjustment method	Screen
32	COLX	4F	Colour maximum value setting	MEMORY 1	A7 signal	Fix	Screen
33	COLC	38	Colour middle value setting (NTSC)	MEMORY 2	A7 signal	Fix	Screen
34	COLP	38	Colour middle value setting (PAL)	MEMORY 2	AV (PAL)	Fix	Screen
35	COLN	00	Colour minimum value setting	Contrast 100 Brightness 50 Colour 0	A7 signal	To make picture without colour	Screen
36	TNTX	6F	NTSC tint maximum value setting	Contrast 100 Tint 100 brightness70 colour 70	A7 signal	Fix	Screen
37	TNTC	38	NTSC tint middle value setting	MEMORY 2	A7 signal	Fix	Screen
38	TNTN	00	NTSC tint minimum value setting	Contrast 100 Tint 0 brightness70 colour 70	A7 signal	Fix	Screen
39	SCOL	04	Sub-colour adjustment	MEMORY 2	A7 signal	Fix	Screen
40	SCNT	0F	Sub-contrast adjustment	MEMORY 2	Gray scale	Fix	Screen
41	ASSH	00	Non-symmetry sharpness			Fix	Screen
42	ABL	27	ABL control (refer to appendix 2 for details)	MEMORY 1	A7 signal	Fix	Screen
43	DEF	01	Set interlace scan to 01	MEMORY 2	A7signal	Fix	Screen
44	FLG 0	52	Refer to appendix 2 for details			Fix	Screen
45	FLG 1	05	Refer to appendix 2 for details			Fix	Screen
46	STBY	00	Refer to appendix 2 for details			Fix	Screen
47	TNCD	40	Tint center (DVD)			Fix	Screen
48	VBLK	00	Refer to appendix 2 for details			Fix	Screen

49	MOD	03	Refer to appendix 2 for details			Fix	Screen
50	UCOM	80	Refer to appendix 2 for details			Fix	Screen
51	MODE 3	80	Refer to appendix 2 for details			Fix	Screen
52	OPT	17	Refer to appendix 2 for details			Fix	Screen
53	OPTM 1 (Refer to appendix 2 for details)	A2	MTS/no GAME			Fix	Screen
		A6	MTS/ GAME				
		22	No MTS/no GAME				
		26	No MTS/ GAME				
		A0	MTS/no GAME/AV3				
		A4	MTS/GAME/AV3				
54	OPTM 2 (Refer to appendix 2 for details)	C5	Rotation/P4.43/N4.43 /M-N		RF:N;AV:P /N	Fix	Screen
		85	Rotation/N-M/P-M/P -N		South America tri-system		
		45	No rotation /N-M/P-4.43/ N-4.43		RF:N;AN:P /N		
		05	No rotation /N-M/P-M/P-N		South America system		
55	TUNR	02	Tuner select			Fix	
56	OSD	18	OSD horizontal position setting		Any TV signal display MENU content	Character in screen center	Screen
57	OSDF	55	OSD oscillation frequency			Fix	
58	CCD OSD	16	CCD horizontal position setting		Display CCD caption	CCD character be in screen center	Screen
59	CCD OSDF	50	CCD OSD oscillation frequency			Fix	
60	ST3	20	NTSC3.58 TV input's sub-sharpness middle value	MEMORY 2	A12	Fix	Screen
61	SV3	30	NTSC3.58 AV input's sub-sharpness middle value	MEMORY 2	AV-N3.58	Fix	Screen

62	SV4	30	Non NTSC3.58 AV input's sub-sharpness middle value	MEMORY 2	AV-P4.43 N4.43	Fix	Screen
63	SVD	30	DVD input's sub-sharpness middle value	MEMORY 2	DVD	Fix	Screen
64	SHPX	1A	Sharpness maximum value setting	Sharpness 100	A12	Fix	Screen
65	SHPN	1D	Sharpness minimum value setting	Sharpness 0	A12	Fix	Screen
66	TXCX	1F	DVD sub-colour maximum value	MEMORY 1	DVD	Fix	Screen
67	RGCN	1F	DVD sub-colour minimum value	MEMORY 2	DVD	Fix	Screen
69	CLTM	0F	Refer to appendix 2 for details	MEMORY 2	A12	Fix	Screen
70	CLVO	4F	Refer to appendix 2 for details	MEMORY 2	AV signal	Fix	Screen
71	CLVD	58	Refer to appendix 2 for details	MEMORY 2	DVD signal	Fix	Screen
72	BRTS	20	Sub-brightness	Contrast 0 Brightness 50 Colour 0	Gray scale	Refer to alignment method	Screen
73	RAGC	30	RF AGC	MEMORY 2	A7	Refer to alignment method	Screen
74	HAFC	05	AFC gain			Fix	Screen
75	VCEN	00	IC output vertical signal center			Fix	
76	NSHP	10	Noise reduction degree	MEMORY 2		Fix	Screen
77	SYCT	08	(TEST)			Fix	
78	NOIS	01	(TEST)			Fix	
79	ONTM	00	POWER ON MUTE TIMER			Fix	
80	V25	36	VOL-25% volume setting	VOL-25	Single tone signal	Fix	
81	V50	40	VOL-50% volume setting	VOL-50	Single tone signal	Fix	
82	V100	76	VOL-100% volume setting	VOL-100	Single tone signal	Refer to adjustment methods	
83	SUR 1	03	At sound register 1's surround sound data			Fix	Not use

84	BASC	30	Bass middle value setting	VOL-50	Sound sweep frequency signal	Fix	
85	BASX	40	Bass maximum value setting	VOL-50		Fix	
86	TREC	39	Treble middle value setting	VOL-50		Fix	
87	BALC	43	Balance center value setting	VOL-50		Fix	
88	WOFC	3D	Woofer middle value setting			Fix	Not use
89	BAS 1	32	At sound register 1's bass data	VOL-50		Fix	
90	BAS 2	5A	At sound register 2's bass data	VOL-50		Fix	
91	TRB 1	32	At sound register 1's treble data	VOL-50		Fix	
92	TRB 2	28	At sound register 2's treble data	VOL-50		Fix	
93	WCTL	30	Woofer control			Fix	Not use
94	WON 1	00	At sound register 1's "woofer on "			Fix	Not use
<p>Note 1: firstly adjust PAL signal (D35) then adjust NTSC signal (A12), and then recheck PAL signal (D35) again, prior to guarantee NTSC signal raster.</p> <p>Note 2: when checking PAL system colour, inputting signal is AV signal.</p>							

Appendix 2: factory adjustment menu remarks

OPTM 1	Bit 0	FJP-SVM USE	0:SVM OUT	1:MONITOR OUT
	Bit 1	AV SELECT	0:AV1-AV2 (DVD)-AV3	1:AV1-AV2-DVD
	Bit 2	FJP-GAME	0:without GAME	1: has GAME
	Bit 3	On-timer indication	0:low level, On-timer ON	1: high level, On-timer ON
	Bit 4			
	Bit 5			
	Bit 6	FJP-M-PAL	0; others	1: Only PAL-M
OPTM 2	Bit 7	FJP-stereo	0: without stereo	1: have stereo
	Bit 0	FJP-Y.U.V	0: without Y.U.V	1: have Y.U.V
	Bit 4	FJP-display button	0: timer display OSD	1: always display
	Bit 5	FJP-woofer	0: without woofer	1: have woofer
	Bit 6	FJP-AUDO 1	0:AUDO 2(35N,M-PAL,N-PAL)	1:AUDO 1(44P,35N,SECAM,44N)
Bit 7	FJP-rotation	0: without rotation	1: have rotation	

ABL	Bit 1,0	ABL gain	00:-0.17V; 01:-0.35V;	10:-0.50V;11:-0.65V;
	Bit 3,2	ABL starting point	00:0V; 01:-0.15V;	10:-0.28V;11:-0.38V
	Bit 4	2IN1 VCD-WPS	0:white peaking value is limited at 105 IRE	1: no limitation to white peaking value
	Bit 5	2IN1 VCD-PGB ABL	0:ABCL has function to OSD	1: without function
FLG 0	Bit 0	OVER MODE SWITCH	0; normal	1:PIF over-modulation switch is connected.
	Bit 1	AFT window	0:OUT OF AFT WINDOW	1:IN THE AFT WINDOW
	Bit 2	Buzz reduction	0:NYQUIST BUZZ CANCEL ON	1:OFF
	Bit 3	Orthogonal detection gain	0: not use	1: not use
	Bit 4	LOCAL SECAM	0: not use	1: not use
	Bit 5	5.65MHz SIF	0: not use	1: not use
	Bit 6	5.74MHz SIF	0: not use	1: not use
FLG 1	Bit 7	Frequency select no need VCO adjustment	0: have VCO	1: without VCO
	Bit 0	CW on/off	0:OFF	1:ON CW OUTPUT FROM IC-26#
	Bit 1	Y OUT ON	0: not use	1: not use
	Bit 2	MIZ GAIN	0:SIF 1MHz CONVERT GAIN, LOW GAIN	1:HIGH GAIN
	Bit 5	C TRAP PASS (TEST)	0: not use	1: not use
	Bit 6	Detection NTSC 3.58	0: not use	1: not use
MOD	Bit 7	TELETEXT	0: not use	1: not use
	Bit 0	CUT OFF gain X10	00: AKB CUT OFF sensitivity X9.75	10:X10.25
	Bit 1		01:X10	11:X10.50
Bit 2	CO MAX	0:CUT OFF range-0.65 TO +6.5	1:-0.65 TO +0.85	
VCOM [CHROMA S/N] (80)	Bit 0	Inner ADC	00:GND	10:B OUT
	Bit 1		01:R OUT	11:MONITOR RF AGC VIA ADC
	Bit 2	REST PATTERN FROM UCOM	0: normal	1:
	Bit 3	USE UCOM SYNC SWITCH	0: normal	1:USE U-COM SYNC
	Bit 4	SYNC TO UCOM	0: not use	1: not use
	Bit 5	V-SWITCH OUT UCOM	0: not use	1: not use
	Bit 6			
MODE 3	Bit 7	OSD HD input polarity selection	0: not use	1: always setting 1
	Bit 4-0	VIDEO MUTE time	MUTE time =data×8 ms	
	Bit 7	VIDEO MUTE type	0:Y MUTE	1:RGB OUT CUT OFF DC

OPT	Bit 0	FBB-MUTE	0:	1: when blue background off, not do MUTE
	Bit 1	FBB-EXMUTE	0:	1: when blue background off, not do EXT-MUTE
	Bit 2	FYMUTE USE	0:	1: when switching channels, use Y-MUTE
	Bit 3	Sound gain SW	0:50Hz	1:500mVrms-25kHz/dev
	Bit 4	Vertical frequency force	0:50Hz	1:60Hz
	Bit 5	SYNC detection way	0: external	1: internal
	Bit 6	Not use		
	Bit 7	SYNC distinguish way	0:	1: gain noise detection
DCBS	Bit 0	Black level stretching point	00:	10:33 IRE
	Bit 1		01:25 IRE	11:43 IRE
	Bit 2	Y-GAMMA	00:OFF	10:82 IRE
	Bit 3		01:Y点 90 IRE,-3dB	11:75 IRE
	Bit 4	OSD level	00:80 IRE	10:60 IRE
	Bit 5		01:70 IRE	11:50 IRE
CLTM [in TV mode]	Bit 0	Y delay (in TV mode)	000: -40ns	100:120ns
	Bit 1		001:0	101:160ns
	Bit 2		010:40ns	110:200ns
			011:80s	111:240ns
	Bit 3	NTSC matrix	00:NTSC 1 (93°)	10,11:FOR DVD
	Bit 4		01:NTSC 2 (108°)	
	Bit 5	C-GAMMA	0: Chroma γ correction off	1: chroma γ correction on (in effect)
	Bit 6	Color killer off	0: normal	1: color killer always off (always have color)
Bit 7	P/N ID	0:P/N color killing sensitivity 1.2/1.5mVp-p	1:6.6/6.4 mVp-p	
CLVO [in AV mode]	Bit 0	Y delay (in AV mode)	000 : -40ns	100:120ns
	Bit 1		001: 0	101:160ns
	Bit 2		010:40ns	110:200ns
			011:80ns	111:240ns
	Bit 3	NTSC matrix	00:NTSC 1(93°)	10,11:FOR DVD
	Bit 4		01:NTSC 2(108°)	
	Bit 5	C-GAMMA	0: chroma γ correction off	1: on
Bit 6	Color killer off	0: normal	1: color killer always off (always have color)	
Bit 7	P/N ID	0:P/N color killing sensitivity 1.2/1.5mVp-p	1:6.6/6.4 mVp-p	

CLVD [in DVD mode]	Bit 0	Y delay (I n DVD mode)	000: -40ns	100:120ns
	Bit 1		001:0	101:160ns
	Bit 2		010:40ns	110:200ns
			011:80ns	111:240ns
	Bit 3	NTSC matrix	00:NTSC 1(93°)	10,11:FOR DVD
	Bit 4		01:NTSC 2(108°)	
	Bit 5	C-GAMMA	0: chroma γ correction off	1: on
	Bit 6	Color killer off	0: normal	1: color killer always off (always have color)
Bit 7	P/N ID	0:P/N color killing sensitivity 1.2/1.5mVp-p	1:6.6/6.4 mVp-p	
NSHP	When NOISE REDUCE ON, sharpness register's content=OSD sharpness value-NSHP value			

USA CHANNEL FREQUENCY TABLE (181 CH)

P IF=45.75 MHz
 C IF=42.17MHz
 S IF=41.25MHz
 UNIT: MHz

BAND	CHANNEL	P CARRIER	S CARRIER	LOCAL	BAND	CHANNEL	P CARRIER	S CARRIER	LOCAL
VHF Low	2	55.25	59.75	101	UHF	W+11	361.25	365.75	407
	3	61.25	65.75	107		W+12	367.25	371.75	413
	4	67.25	71.75	113		W+13	373.25	377.75	419
	5	77.25	81.75	123		W+14	379.25	383.75	425
	6	83.25	87.75	129		W+15	385.25	389.75	431
	A-6	85.25	89.75	131		W+16	391.25	395.75	437
	A-5	91.25	95.75	137		W+17	397.25	401.75	443
	A-4	97.25	101.75	143		W+18	403.25	407.75	449
	A-3	103.25	107.75	149		W+19	409.25	413.75	455
	A-2	109.25	113.75	155		W+20	415.25	419.75	461
	A-1	115.25	119.75	161		W+21	421.25	425.75	467
	A	121.25	125.75	167		W+22	427.25	431.75	473
	B	127.25	131.75	173		W+23	433.25	437.75	479
	VHF High	C	133.25	137.75		179	W+24	439.25	443.75
D		139.25	143.75	185		W+25	445.25	449.75	491
E		145.25	149.75	191		W+26	451.25	455.75	497
F		151.25	155.75	197		W+27	457.25	461.75	503
G		157.25	161.75	203		W+28	463.25	467.75	509
H		163.25	167.75	209		W+29	469.25	473.75	515
I		169.25	173.75	215		14	471.25	475.75	517
7		175.25	179.75	221		15	477.25	481.75	523
8		181.25	185.75	227		16	483.25	487.75	529
9		187.25	191.75	233		17	489.25	493.75	535
10		193.25	197.75	239		18	495.25	499.75	541
11		199.25	203.75	245		19	501.25	505.75	547
12		205.25	209.75	251		20	507.25	511.75	553
13		211.25	215.75	257		21	513.25	517.75	559
J		217.25	221.75	263		22	519.25	523.75	565
K		223.25	227.75	269		23	525.25	529.75	571
L		229.25	233.75	275		24	531.25	535.75	577
M		235.25	239.75	281		25	537.25	541.75	583
N		241.25	245.75	287		26	543.25	547.75	589
O		247.25	251.75	293		27	549.25	553.75	595
P		253.25	257.75	299		28	555.25	559.75	601
Q		259.25	263.75	305		29	561.25	565.75	607
R		265.25	269.75	311		30	567.25	571.75	613
S		271.25	275.75	317		31	573.25	577.75	619
T		277.25	281.75	323		32	579.25	583.75	625
U		283.25	287.75	329		33	585.25	589.75	631
V		289.25	293.75	335		34	591.25	595.75	637
W		295.25	299.75	341		35	597.25	601.75	643
W+1		301.25	305.75	347		36	603.25	607.75	649
W+2		307.25	311.75	353		37	609.25	613.75	655
W+3		313.25	317.75	359		38	615.25	619.75	661
W+4		319.25	323.75	365		39	621.25	625.75	667
W+5		325.25	329.75	371	40	627.25	631.75	673	
W+6		331.25	335.75	377	41	633.25	637.75	679	
W+7	337.25	341.75	383	42	639.25	643.75	685		
W+8	343.25	347.75	389	43	645.25	649.75	691		
W+9	349.25	353.75	395	44	651.25	655.75	697		
W+10	355.25	359.75	401	45	657.25	661.75	703		

USA CHANNEL FREQUENCY TABLE (181 CH)

P IF=45.75 MHz
 C IF=42.17MHz
 S IF=41.25MHz

UNIT: MHz

BAND	CHANNEL	P CARRIER	S CARRIER	LOCAL
UHF	46	663.25	667.75	709
	47	669.25	673.75	715
	48	675.25	679.75	721
	49	681.25	685.75	727
	50	687.25	691.75	733
	51	693.25	697.75	739
	52	699.25	703.75	745
	53	705.25	709.75	751
	54	711.25	715.75	757
	55	717.25	721.75	763
	56	723.25	727.75	769
	57	729.25	733.75	775
	58	735.25	739.75	781
	59	741.25	745.75	787
	60	747.25	751.75	793
	61	753.25	757.75	799
	62	759.25	763.75	805
	63	765.25	769.75	811
	64	771.25	775.75	817
	65	777.25	781.75	823
66	783.25	787.75	829	
67	789.25	793.75	835	
68	795.25	799.75	841	
69	801.25	805.75	847	

WIRING DIAGRAM

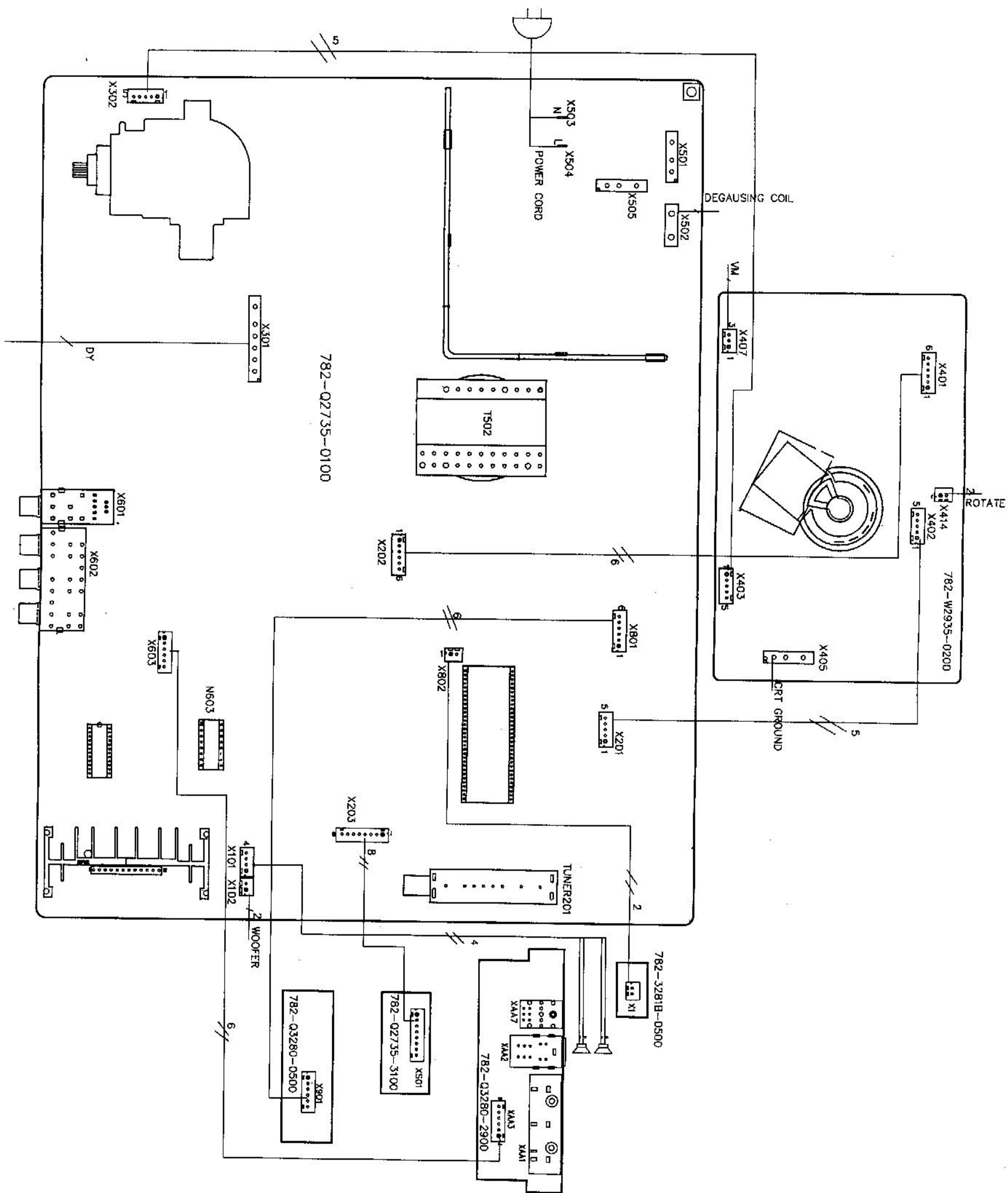

BLOCK DIAGRAM

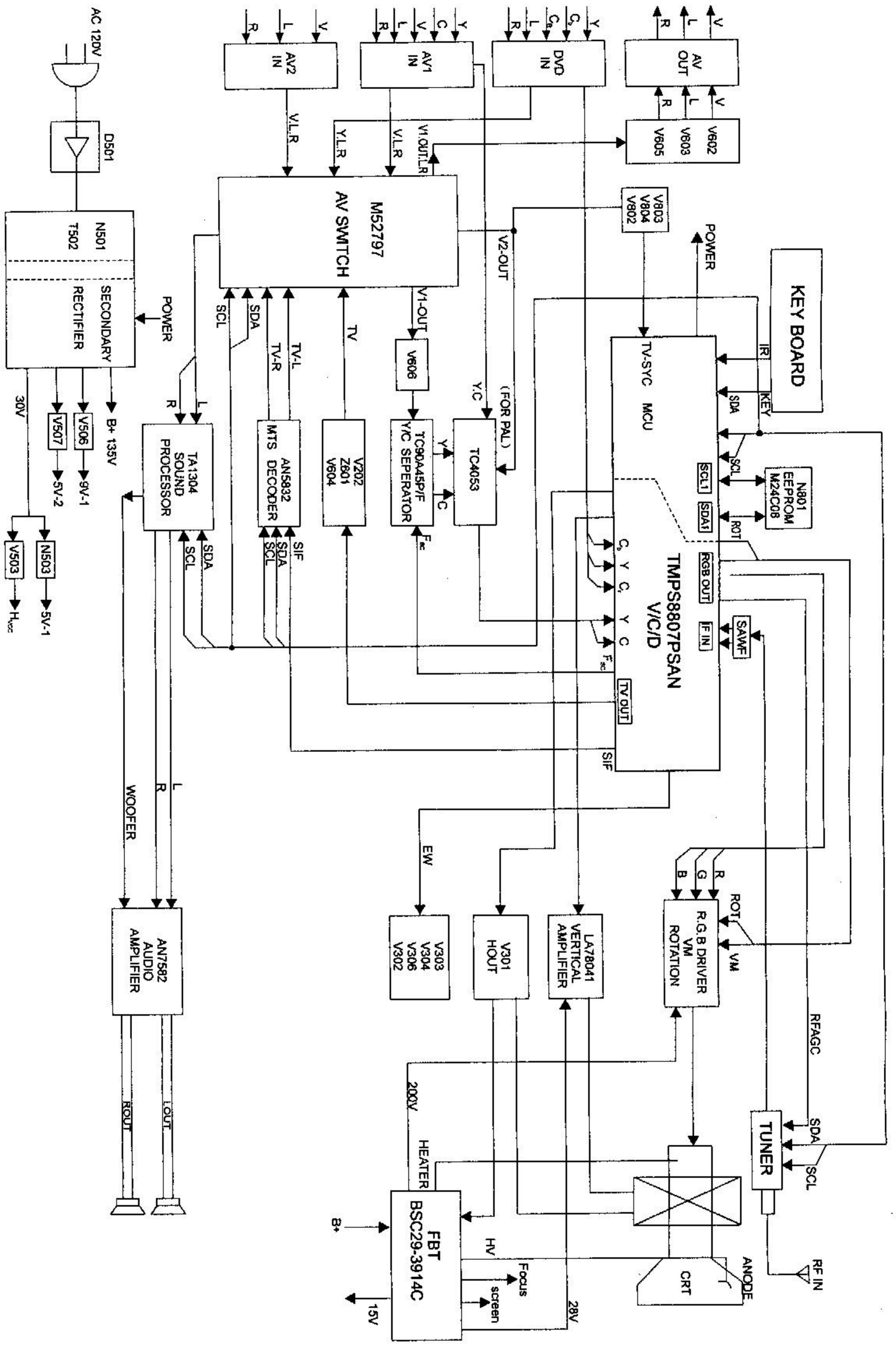

IC BLOCK DIAGRAM

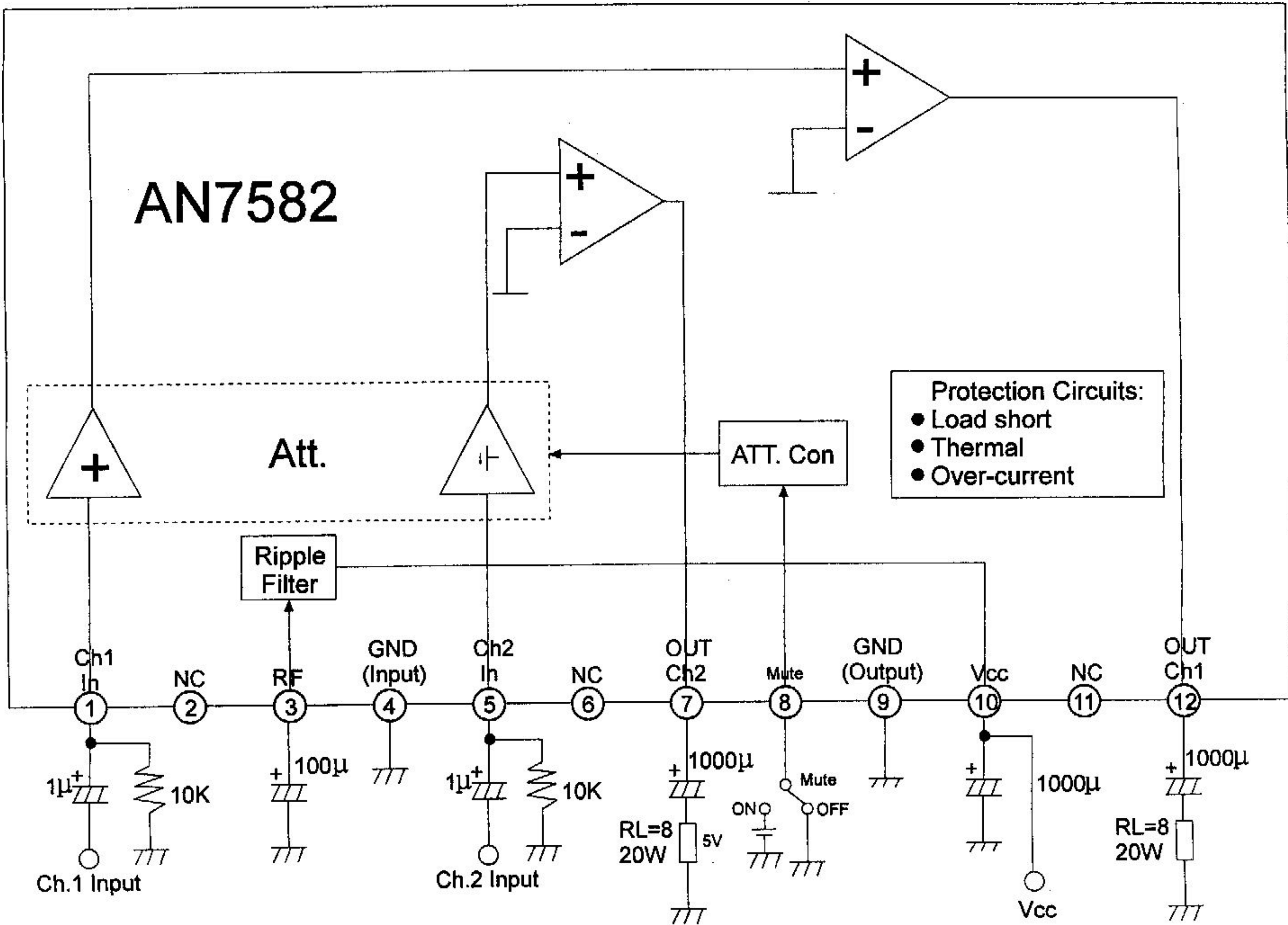

NOTE: For MUTE "OFF", connect MUTE to 0V.

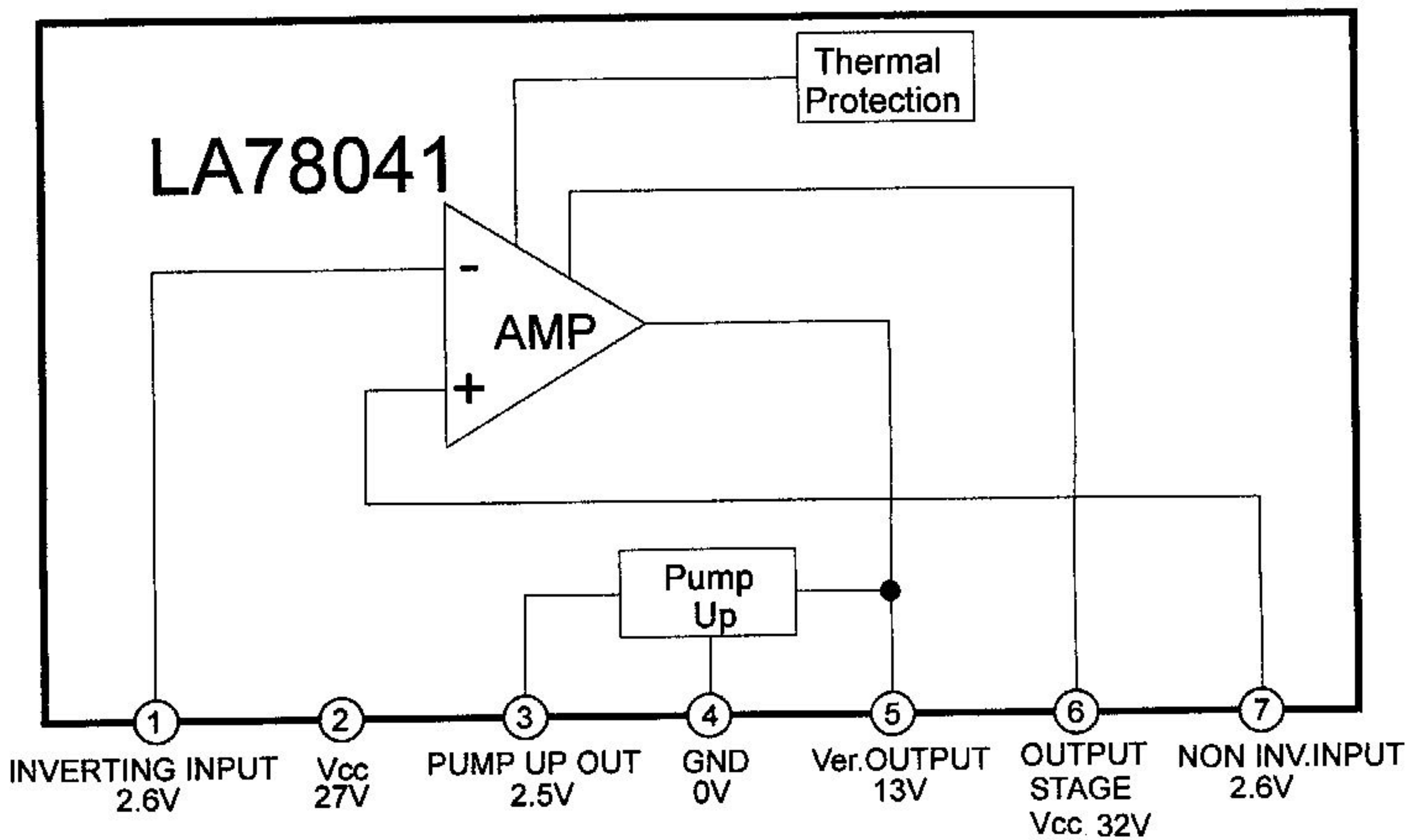

TMPA8807

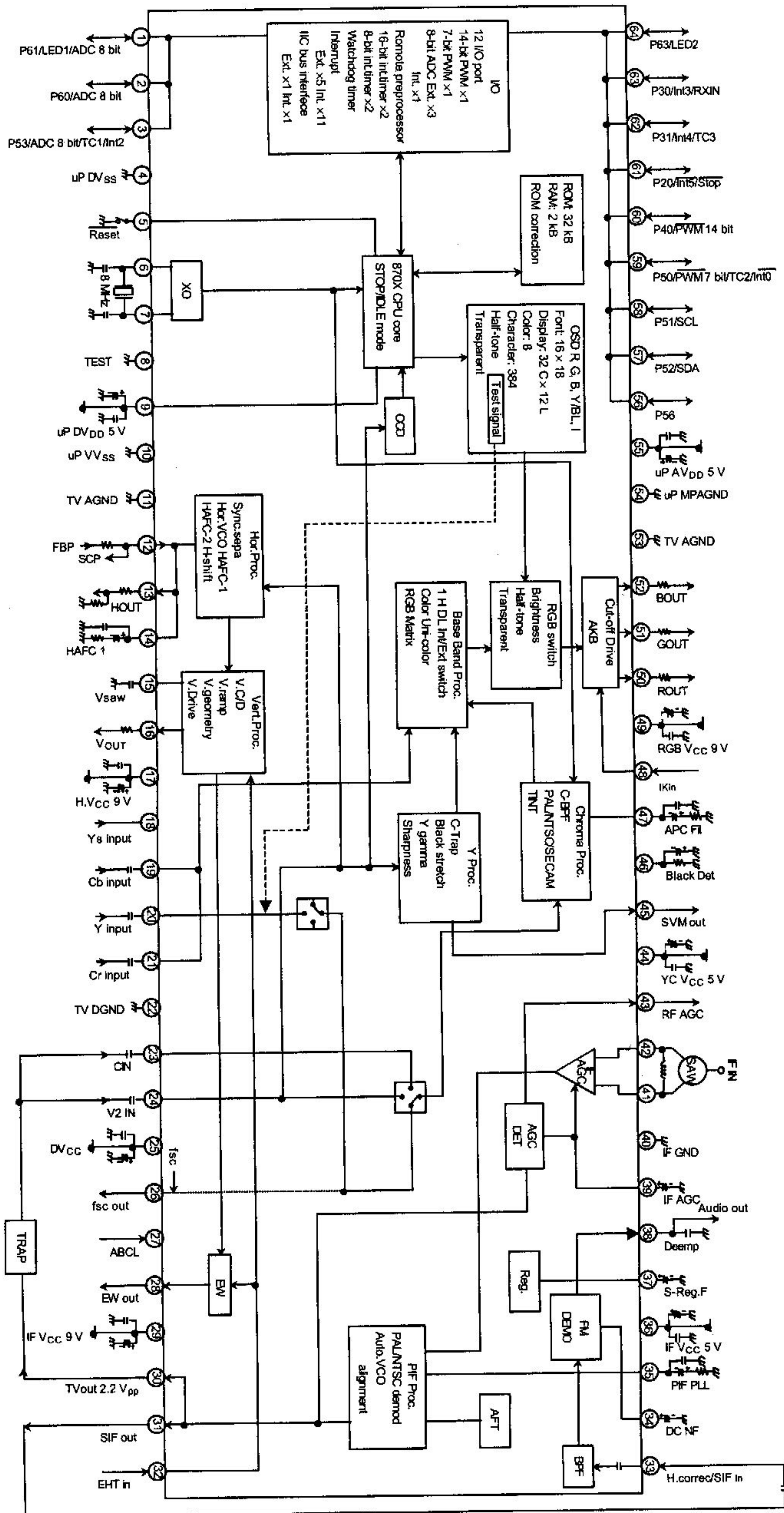

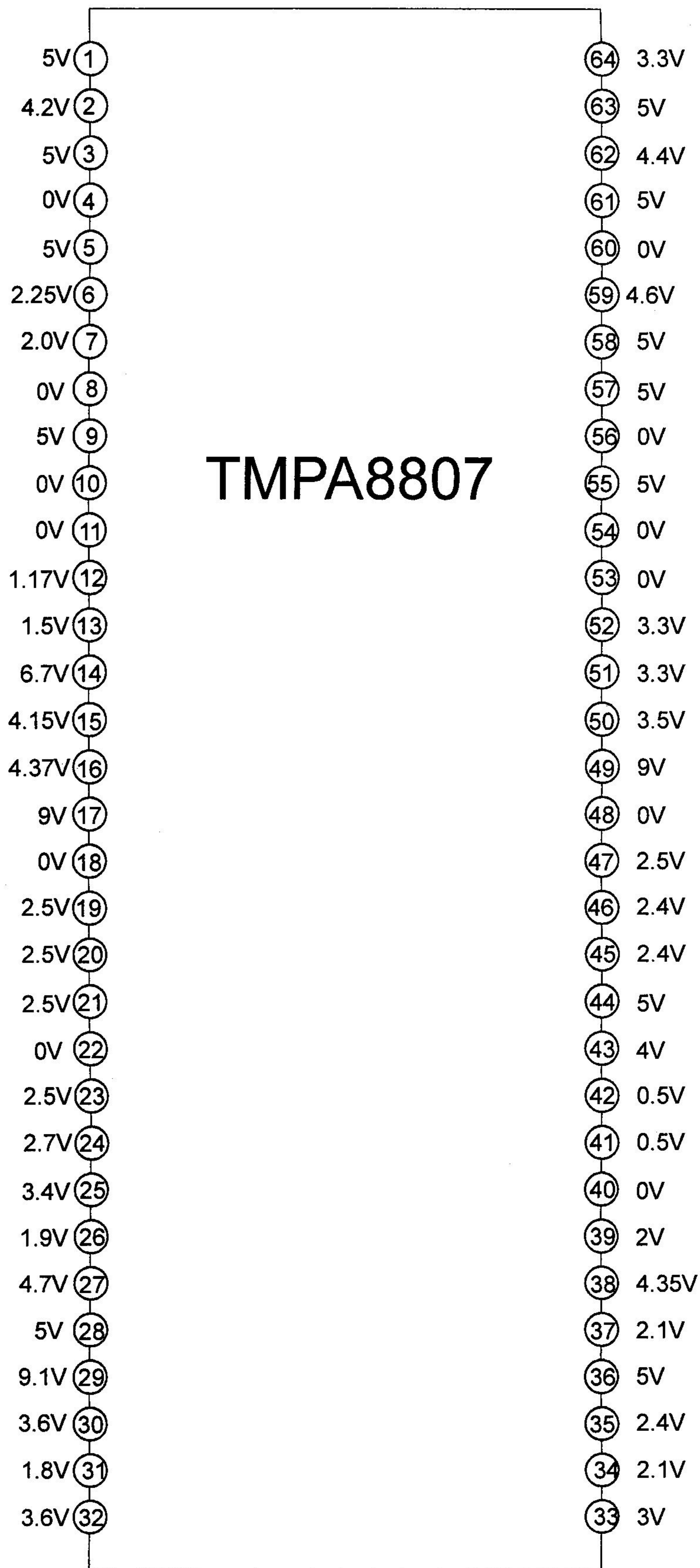

TA1304F/N

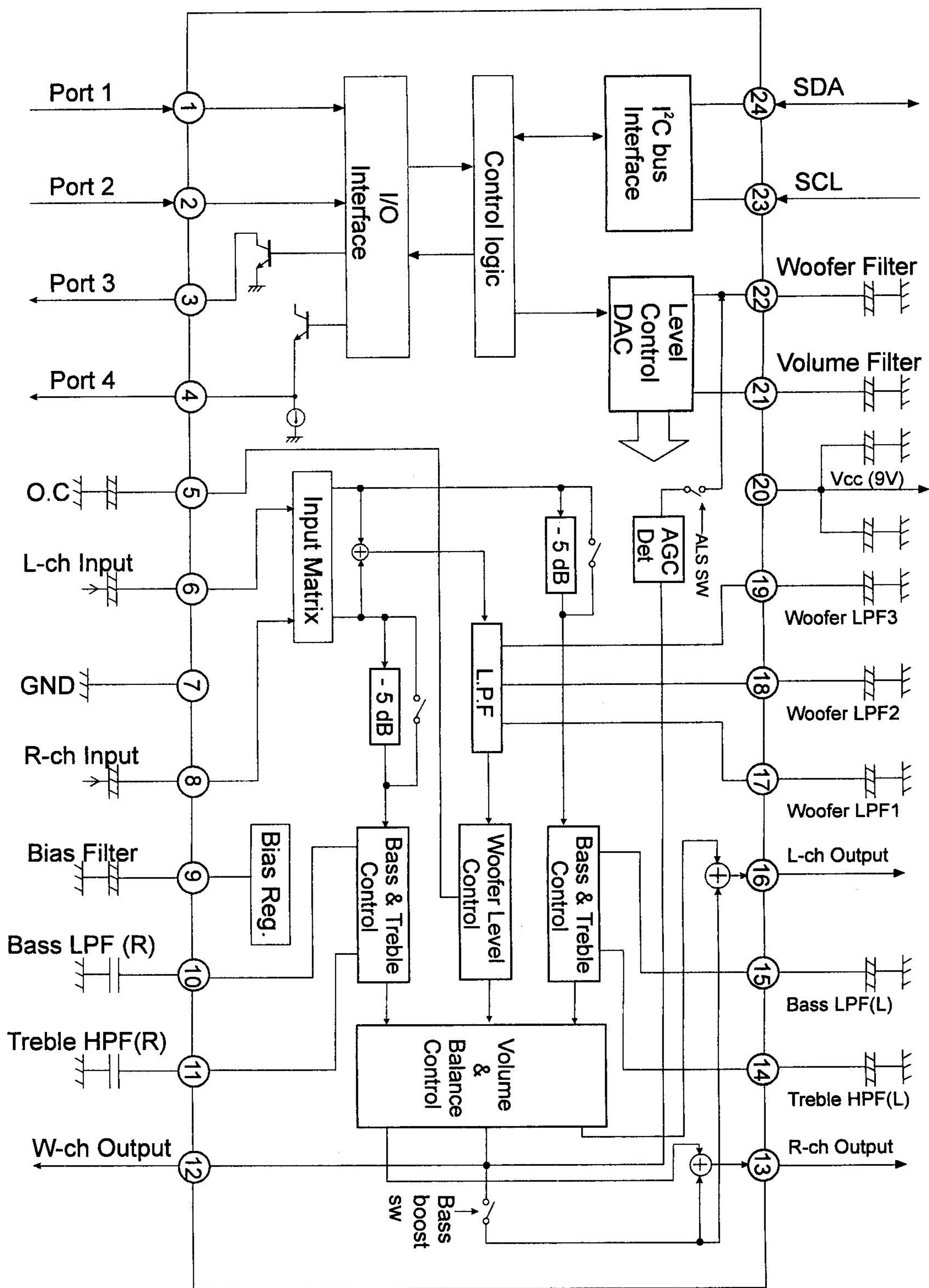

STR-G9656

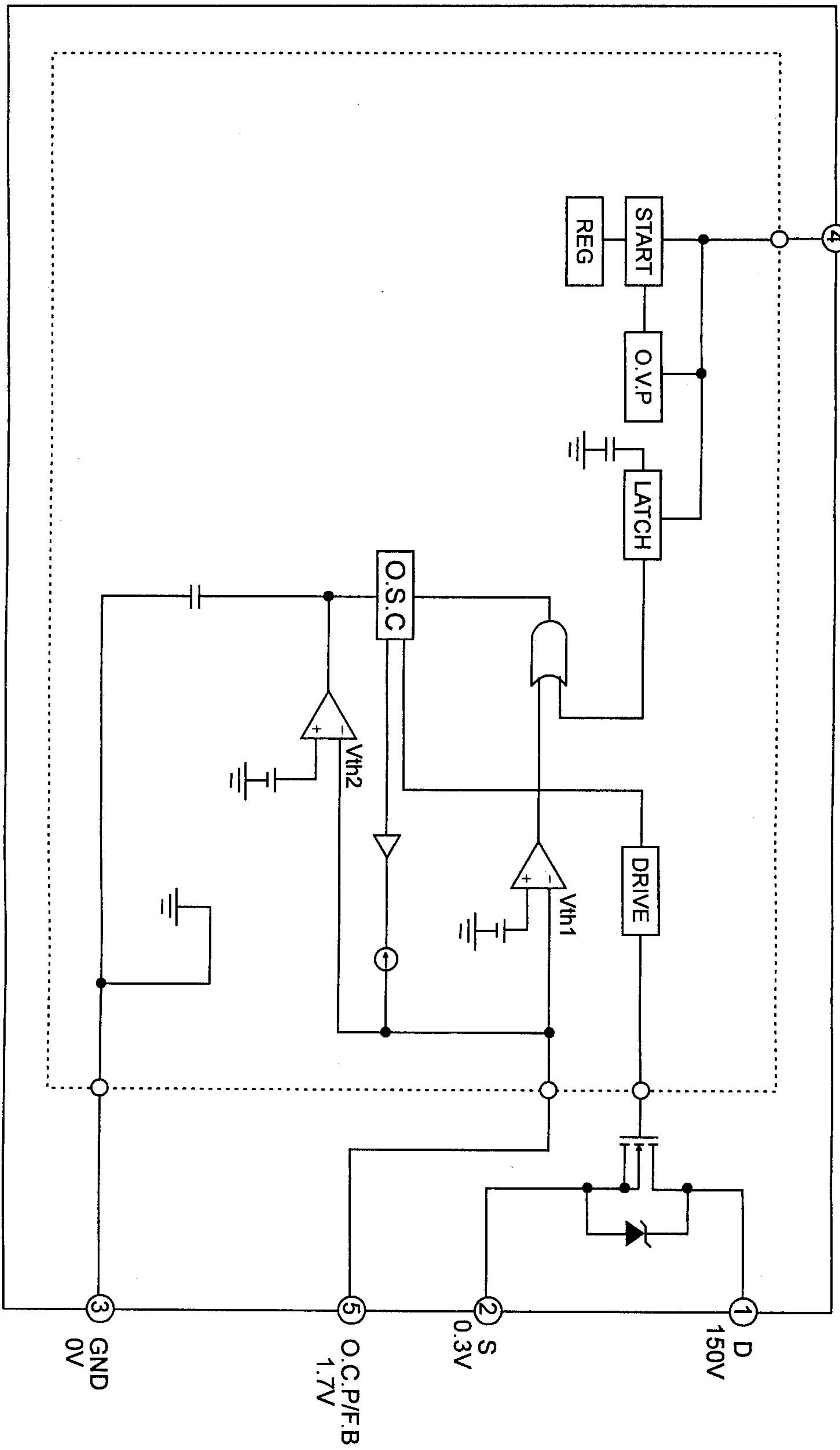

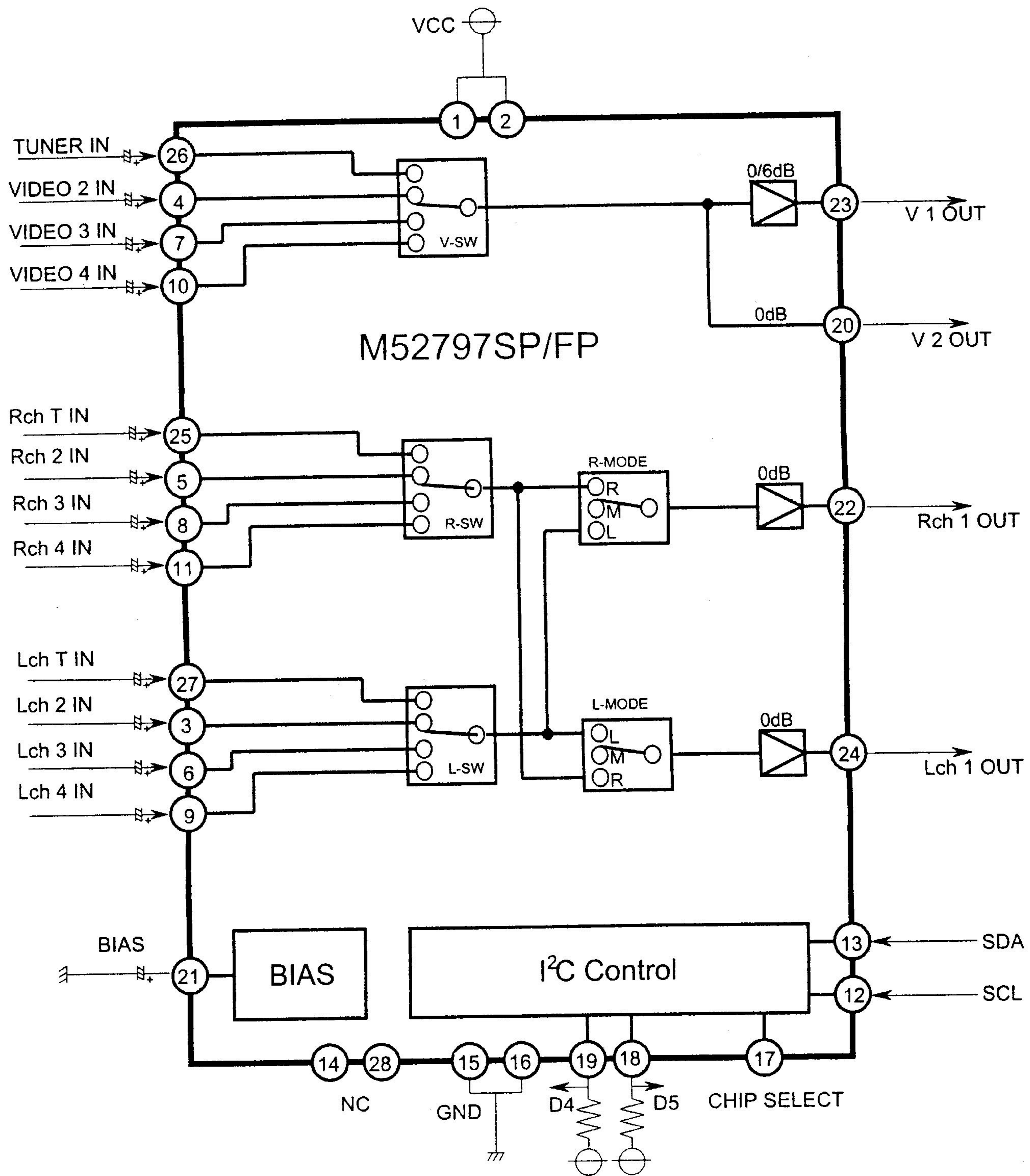

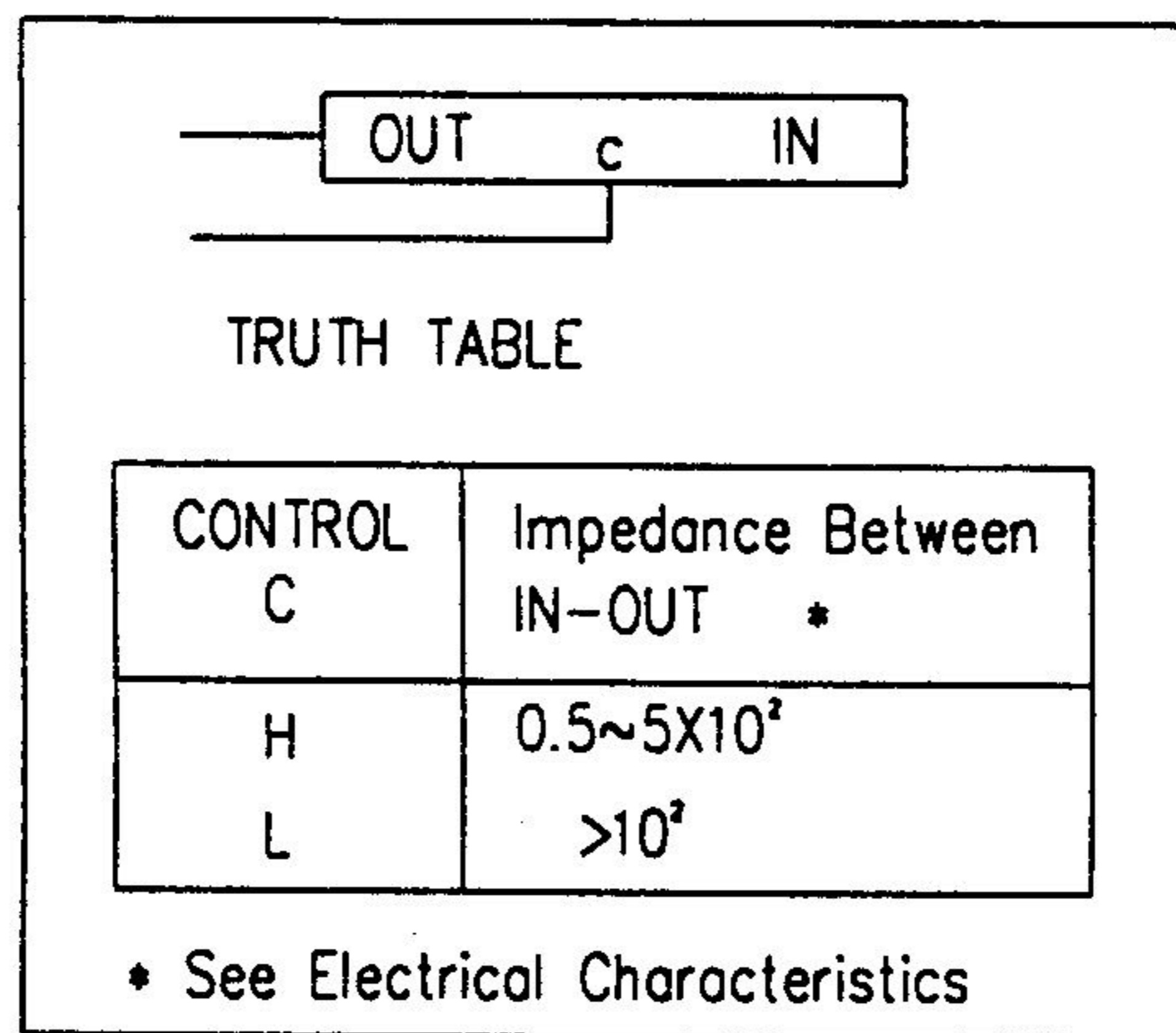
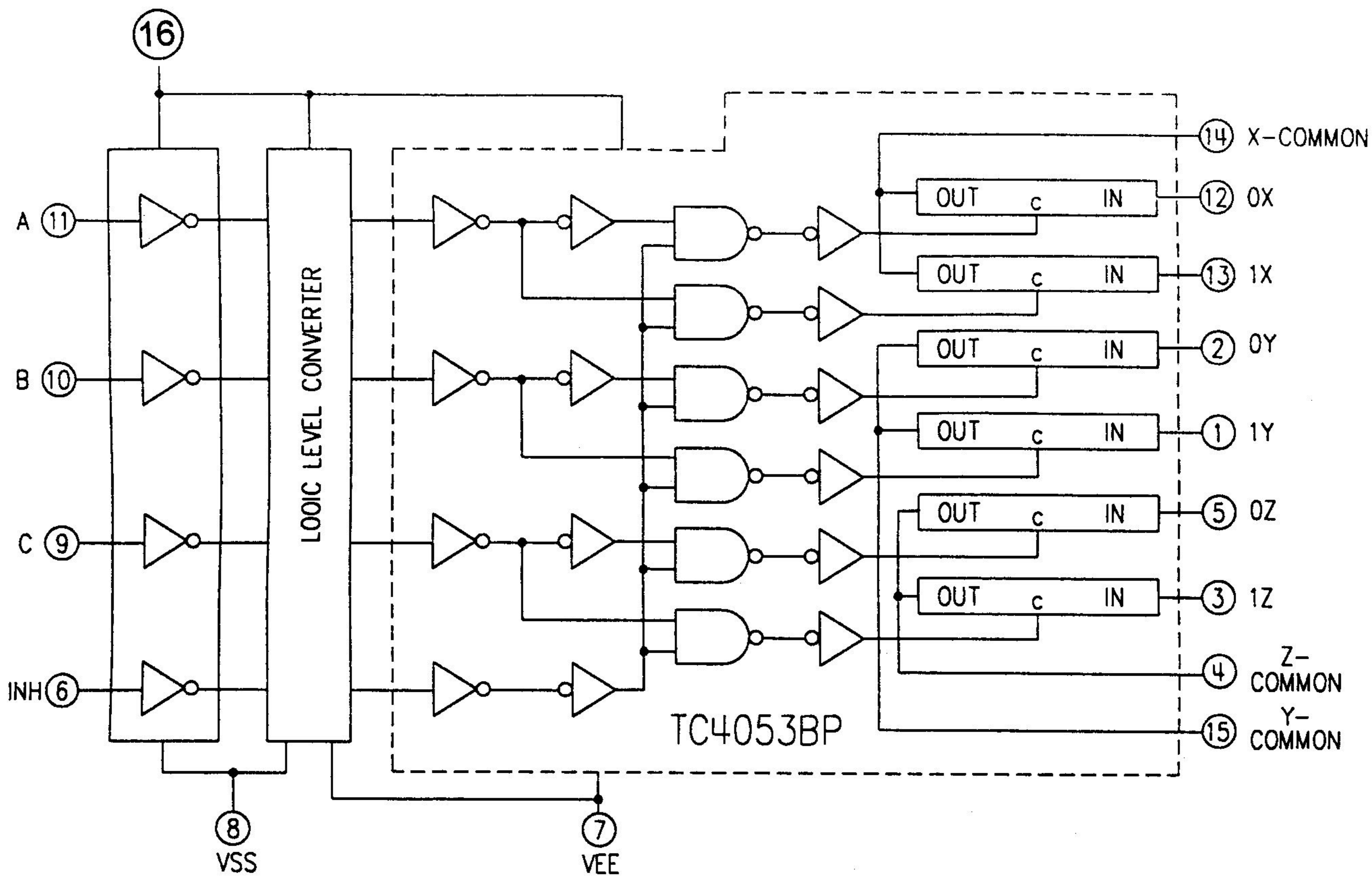

TC90A45P/F

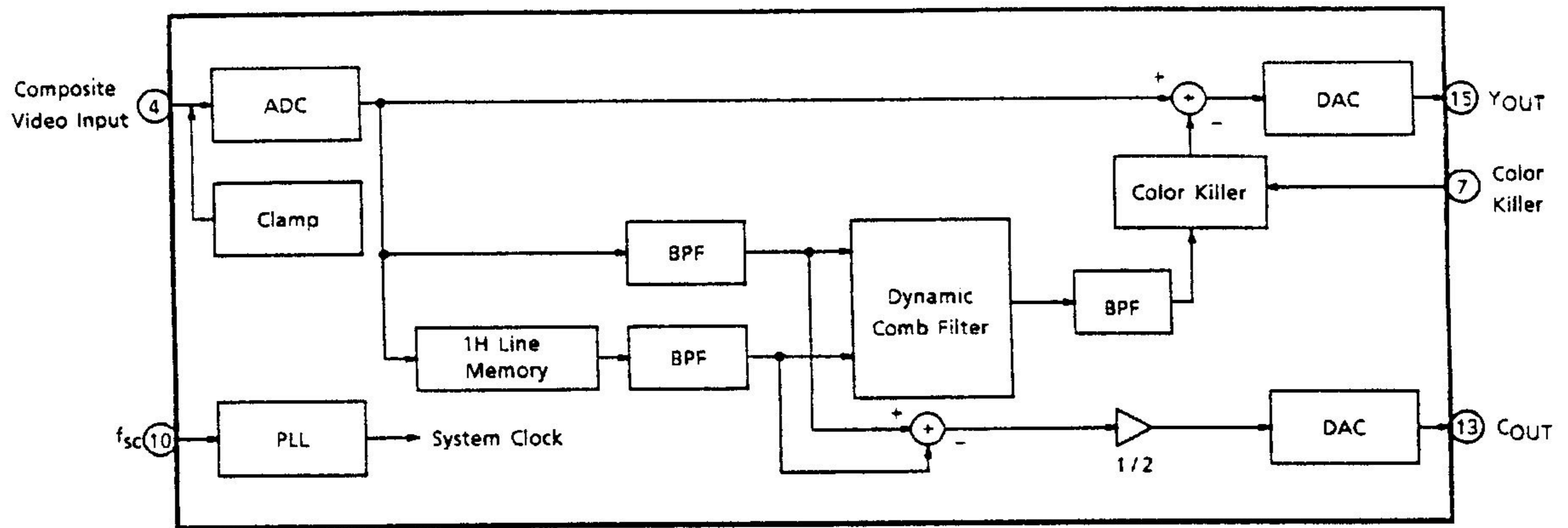

TERMINAL CONNECTION DIAGRAM

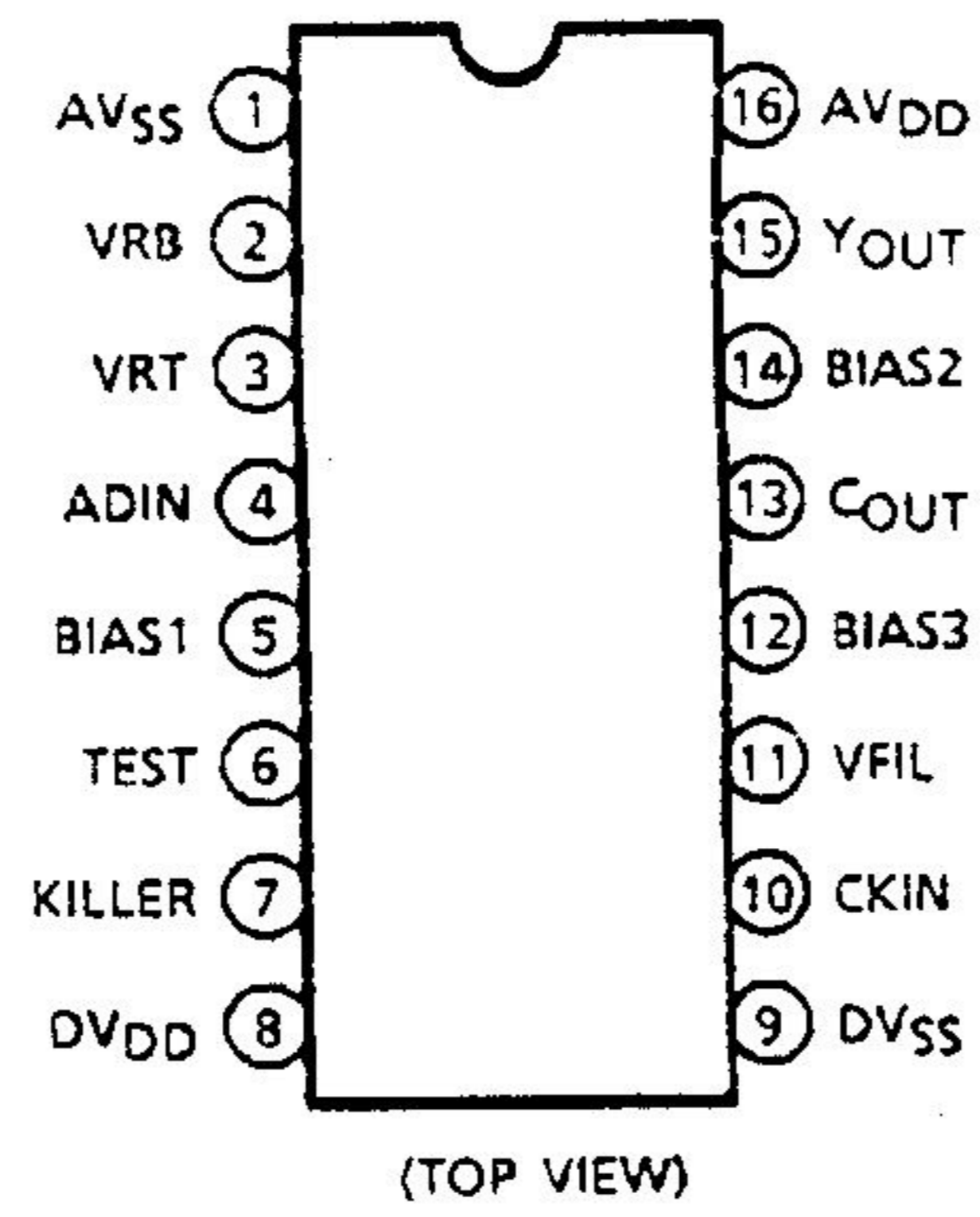

782-Q328
MAIN BOARD
2003.1.8

667-62735-3100
X203

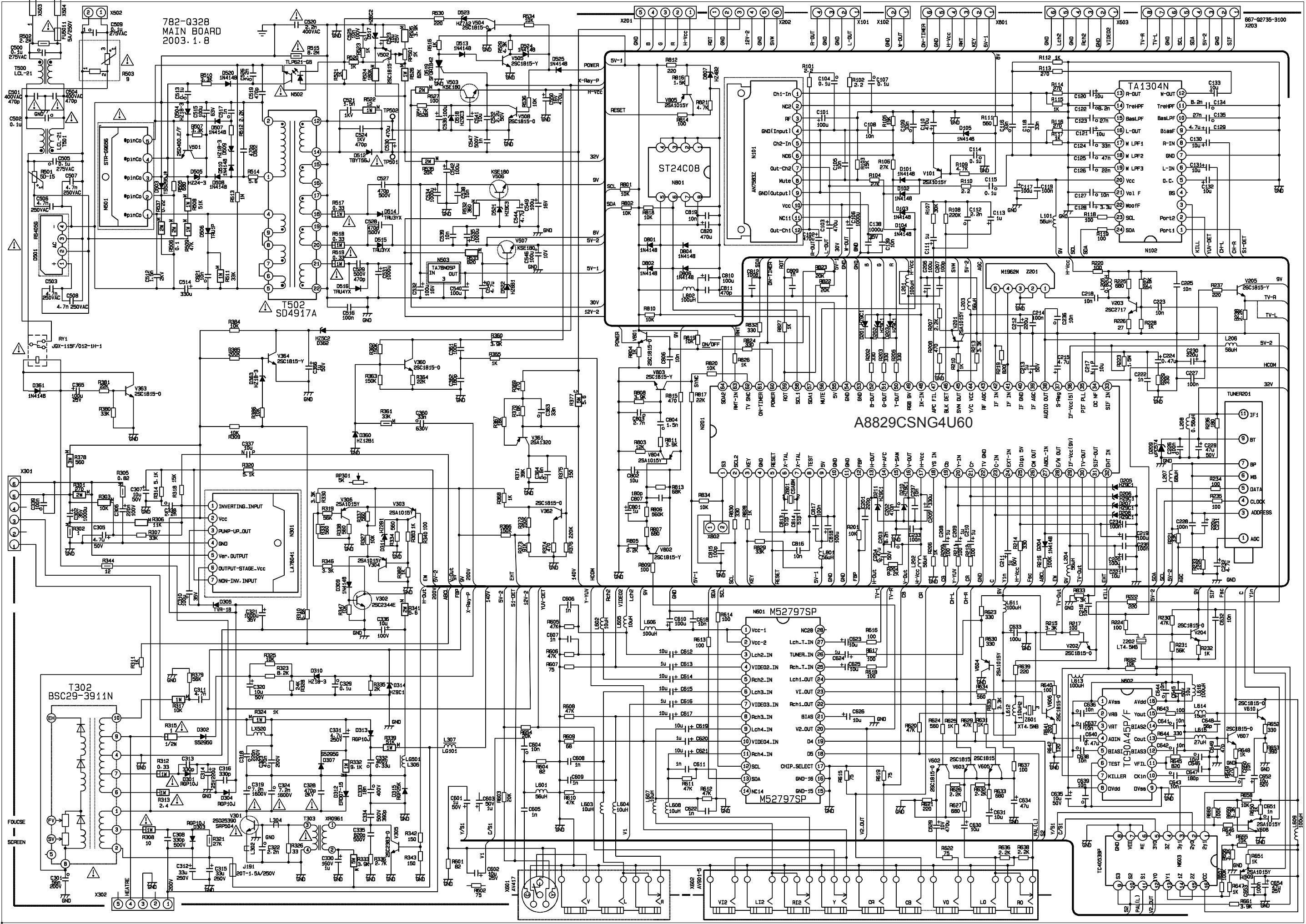

WARNING: BEFORE SERVICING THIS CHASSIS, READ THE “X-RAY RADIATION PERCAUTION”, “SAFETY PRECAUTION” AND “PRODUCT SAFETY NOTICE” ON PAGE 1&2 OF THIS MANUAL.

CAUTION: 1. The shaded areas makes in the schematic diagram and the parts list designate components which have special characteristics important for safety and should be replaced only with type identical to those in the original circuit or specified in the parts list. Before replacing any of these components, read carefully the PRODUCT SAFETY NOTICE on page 2.
2. Do not degrade the safety of the receiver through improper servicing.

ELECTRICAL PARTS LIST

MAIN BOARD

SYMBOL	PART NO.	DESCRIPTION
	782-Q2735-010	MAIN PCB
CRYSTAL		
Z801	329-58001-00	8MHZ
RECTIFIER		
D506	340-80010-00	RUIP
D501	340-80019-00	T3SB60
DIODE		
D304	340-00288-00	TFR155
D315	340-00257-00	BYT56J
D512	340-00257-00	BYT56J
D514	340-00283-00	TRU3YX
D515	340-00283-00	TRU3YX
D516	340-00284-00	TRU4YX
D312	340-00297-00	ERD07-15
D309	340-00001-003	1N4148
D103	340-00001-003	1N4148
D104	340-00001-003	1N4148
D806	340-00001-003	1N4148
D804	340-00001-003	1N4148
D802	340-00001-003	1N4148
D801	340-00001-003	1N4148
D204	340-00001-003	1N4148
D524	340-00001-003	1N4148

SYMBOL	PART NO.	DESCRIPTION
D525	340-00001-003	1N4148
D510	340-00001-003	1N4148
D508	340-00001-003	1N4148
D507	340-00001-003	1N4148
D101	340-00001-003	1N4148
D102	340-00001-003	1N4148
D105	340-00001-003	1N4148
D361	340-00001-003	1N4148
D513	340-00001-003	1N4148
D520	340-00001-003	1N4148
D307	340-00010-003	S5295G
D302	340-00010-003	S5295G
D313	340-00288-003	TFR155
D301	340-00288-003	TFR155
D303	340-00288-003	TFR155
D305	340-00086-003	TVR-1B
D503	340-00005-003	S5295J
REGULATED DIODE		
D362	340-50510-003	HZ5C2
D311	340-50270-003	HZ3A2
D807	340-50390-003	HZ4B2
D522	340-50560-003	HZ6B1
D517	340-50610-003	HZ6C2
D523	340-50650-003	HZ7A2
D203	340-50820-003	HZ9A3
D202	340-50820-003	HZ9A3
D201	340-50820-003	HZ9A3
D207	340-50820-003	HZ9A3
D208	340-50820-003	HZ9A3
D211	340-50820-003	HZ9A3
D205	340-50820-003	HZ9A3
D206	340-50820-003	HZ9A3
D314	340-50910-003	HZ9C1
D210	340-50910-003	HZ9C1
D518	340-50950-003	HZ9C3
D521	340-50950-003	HZ9C3
D360	340-51260-003	HZ12B1
D310	340-51850-003	HZ18-3
D509	340-51850-003	HZ18-3
D504	340-51850-003	HZ18-3

SYMBOL	PART NO.	DESCRIPTION
D363	340-51850-003	HZ18-3
D505	340-52490-003	HZ24-3
TRANSISTOR		
V503	343-01800-00	KSE180 TO-126
V507	343-01800-00	KSE180 TO-126
V506	343-01800-00	KSE180 TO-126
V361	343-13200-00	2SA1320
V305	343-23830-60	2SC2383-0
V301	343-25390-00	2SD2539
V203	343-27170-00	2SC2717
V302	343-38520-00	2SC3852
D519	343-00420-404	SFORIB42
V501	343-04000-304	2SD400 E/F
V608	343-10150-104	2SA1015Y Pr2.5
V609	343-10150-104	2SA1015Y Pr2.5
V805	343-10150-104	2SA1015Y Pr2.5
V804	343-10150-104	2SA1015Y Pr2.5
V304	343-10150-104	2SA1015Y Pr2.5
V303	343-10150-104	2SA1015Y Pr2.5
V306	343-10150-104	2SA1015Y Pr2.5
V604	343-10150-104	2SA1015Y Pr2.5
V201	343-10150-104	2SA1015Y Pr2.5
V101	343-10150-104	2SA1015Y Pr2.5
V802	343-18150-114	2SC1815-Y
V803	343-18150-114	2SC1815-Y
V502	343-18150-114	2SC1815-Y
V363	343-18150-114	2SC1815-Y
V360	343-18150-114	2SC1815-Y
V364	343-18150-114	2SC1815-Y
V505	343-18150-114	2SC1815-Y
V801	343-18150-604	2SC 1815-0
V610	343-18150-604	2SC 1815-0
V204	343-18150-604	2SC 1815-0
V607	343-18150-604	2SC 1815-0
V606	343-18150-604	2SC 1815-0
V202	343-18150-604	2SC 1815-0
V602	343-18150-604	2SC 1815-0
V603	343-18150-604	2SC 1815-0
V605	343-18150-604	2SC 1815-0
V504	343-18150-604	2SC 1815-0

SYMBOL	PART NO.	DESCRIPTION
V508	343-18150-604	2SC 1815-0
V362	343-18150-604	2SC 1815-0
CERAMIC CAPACITOR		
C501	459-B147M-20	ECK-DNS471MBX
C504	459-B147M-20	ECK-DNS471MBX
C520	459-B222M-20	ECK-DNS222MEX
C507	459-B247R-00	DE0807F472ZAC250V
C503	459-B247R-00	DE0807F472ZAC250V
C508	459-B247R-00	DE0807F472ZAC250V
C506	459-B247R-00	DE0807F472ZAC250V
C313	459-5133K-00	RQC05B331K-H46CA
C524	459-6147K-00	DE0705B471K1k
C521	459-6133K-00	DE0405B331K1K
C328	459-8210K-00	DE0907B102K2K
C512	459-8215K-00	DE1007B152K2K
C649	459-2047H-102	CC45-CH1H470JYR
C814	459-2051H-102	CC1-08-CH-63V-51pF-J
C813	459-2051H-102	CC1-08-CH-63V-51pF-J
C648	459-2056H-102	CC1-08-CH-63V-56pF-J
C815	459-2110H-102	CC45-CH1H101JYR
C812	459-2110H-102	CC45-CH1H101JYR
C647	459-2118H-102	CC45-CH1H181JYR
C807	459-2118H-102	CC45-CH1H181JYR
C362	459-2118H-102	CC45-CH1H181JYR
C519	459-2147H-902	CC1-12-SL-63V-471J
C525	459-2210K-002	CK45-B1H102KYR
C222	459-2210K-002	CK45-B1H102KYR
C608	459-2210K-002	CK45-B1H102KYR
C609	459-2210K-002	CK45-B1H102KYR
C611	459-2210K-002	CK45-B1H102KYR
C622	459-2210K-002	CK45-B1H102KYR
C605	459-2210K-002	CK45-B1H102KYR
C218	459-2310R-002	CK45-F1H103ZYR
C223	459-2310R-002	CK45-F1H103ZYR
C225	459-2310R-002	CK45-F1H103ZYR
C538	459-2310R-002	CK45-F1H103ZYR
C539	459-2310R-002	CK45-F1H103ZYR
C618	459-2310R-002	CK45-F1H103ZYR
C216	459-2310R-002	CK45-F1H103ZYR
C806	459-2310R-002	CK45-F1H103ZYR

SYMBOL	PART NO.	DESCRIPTION
C819	459-2310R-002	CK45-F1H103ZYZR
C108	459-2310R-002	CK45-F1H103ZYZR
C105	459-2310R-002	CK45-F1H103ZYZR
C139	459-2310R-002	CK45-F1H103ZYZR
C604	459-2310R-002	CK45-F1H103ZYZR
C632	459-2310R-002	CK45-F1H103ZYZR
C228	459-2410R-002	DD308-63F104Z50
C227	459-2410R-002	DD308-63F104Z50
C207	459-2410R-002	DD308-63F104Z50
C811	459-2410R-002	DD308-63F104Z50
C214	459-2410R-002	DD308-63F104Z50
C639	459-2410R-002	DD308-63F104Z50
C329	459-2410R-002	DD308-63F104Z50
C817	459-2410R-002	DD308-63F104Z50
C234	459-2410R-002	DD308-63F104Z50
C235	459-2410R-002	DD308-63F104Z50
C119	459-2410R-002	DD308-63F104Z50
C233	459-2410R-002	DD308-63F104Z50
C653	459-2410R-002	DD308-63F104Z50
C516	459-2410R-002	DD308-63F104Z50
C127	459-2410R-002	DD308-63F104Z50
C816	459-2410R-002	DD308-63F104Z50
C308	459-5133K-002	RQC05B331K-H46CA
C316	459-5133K-002	RQC05B331K-H46CA
C334	459-5139K-002	CK45-B2H391KYR
C529	459-5147K-002	RQC05B471K-H46CA
C528	459-5147K-002	RQC05B471K-H46CA
C527	459-5147K-002	RQC05B471K-H46CA
C822	459-5147K-002	RQC05B471K-H46CA
C547	459-5210K-002	CK45-B2H102KYR
C335	459-5182K-002	DD06-999B812K500
THIN-FILM CAPACITOR		
C339	462-B0410-H0	CL21X-50V-0.1uF-J
C202	462-B0447-H0	CL21X-50V-0.47uF-J
C804	462-00215-K0	CL11-100V-1500PF-K
C803	462-00227-K0	CL11-100V-2700PF-K
C203	462-00282-H0	CL11-100V-8200pF-J
C122	462-00282-H0	CL11-100V-8200pF-J
C134	462-00282-H0	CL11-100V-8200pF-J
C502	462-2B410-M0V	250VAC-0.1uF-M

SYMBOL	PART NO.	DESCRIPTION
C505	462-2B410-M0V	250VAC-0.1uF-M
C509	462-2B410-M0V	250VAC-0.1uF-M
C821	462-26310-K0	CL21-630V-0.01uF-K
C319	462-8E282-H0	CBB81-2KV-8200PF-J
C324	462-8E282-H0	CBB81-2KV-8200PF-J
C301	462-83356-H0	CBB21-200V-0.056uF-J
C323	462-83447-H0	CBB21-200V-0.47uF-J
C333	462-85318-H0	CBB21-400V-0.018uF-J
C360	462-85333-H0	CBB21-400V-0.033uF-J
C332	462-85433-H0	CBB21-400V-0.33uF-J
C226	462-B0410-H02	CL21X-50V-0.1uF-J
C361	462-B0410-H02	CL21X-50V-0.1uF-J
C104	462-B0410-H02	CL21X-50V-0.1uF-J
C115	462-B0410-H02	CL21X-50V-0.1uF-J
C513	462-B0410-H02	CL21X-50V-0.1uF-J
C114	462-B0410-H02	CL21X-50V-0.1uF-J
C306	462-B0422-H02	CL21X-50V-0.22uF-J
C651	462-00210-H02	CL11-100V-1000PF-J
C517	462-00210-H02	CL11-100V-1000PF-J
C338	462-00222-H02	CL11-100V-2200PF-J
C112	462-00222-H02	CL11-100V-2200PF-J
C322	462-00222-K02	CL11-100V-2200PF-K
C311	462-00247-K02	CL11-100V-4700PF-K
C364	462-00256-H02	CL11-100V-5600PF-J
C526	462-00256-H02	CL11-100V-5600PF-J
C646	462-00310-H02	CL11-100V-0.01uF-J
C636	462-00310-H02	CL11-100V-0.01uF-J
C637	462-00310-H02	CL11-100V-0.01uF-J
C638	462-00310-H02	CL11-100V-0.01uF-J
C641	462-00310-H02	CL11-100V-0.01uF-J
C642	462-00310-H02	CL11-100V-0.01uF-J
C643	462-00310-H02	CL11-100V-0.01uF-J
C644	462-00310-H02	CL11-100V-0.01uF-J
C650	462-00310-H02	CL11-100V-0.01uF-J
C236	462-00310-H02	CL11-100V-0.01uF-J
C237	462-00310-H02	CL11-100V-0.01uF-J
C126	462-00322-H02	CL11-100V-0.022uF-J
C123	462-00327-H02	CL11-100V-0.027uF-J
C135	462-00327-H02	CL11-100V-0.027uF-J
C118	462-00333-H02	CL11-100V-0.033uF-J

SYMBOL	PART NO.	DESCRIPTION
C109	462-00333-H02	CL11-100V-0.033uF-J
C124	462-00333-H02	CL11-100V-0.033uF-J
C363	462-00333-H02	CL11-100V-0.033uF-J
C125	462-00347-H02	CL11-100V-0.047uF-J
C500	462-2B422-M1V	250VAC-0.22uF-M
C522	462-B0510-H0	CL21X-50V-1uF-J
ELECTROLYTIC CAPACITOR		
C331	464-65547-M0	CD288-250V-4.7uF-M
C315	464-65633-M0	CD288-250V-33uF-M
C312	464-65633-M0	CD288-250V-33uF-M
C336	464-V1610-T0	CD111HR-100V-10uF-T
C530	464-04747-M0R	200USP470MA35
C514	464-07733-M0N	CD293X-400V-330uF-M
C337	464-3D610-M0	CD11W-16V-10uF-M
C217	464-3D610-M0	CD11W-16V-10uF-M
C206	464-6D710-M0	CD110-16V-100uF-M
C212	464-6D722-M0	CD110-16V-220uF-M
C230	464-6D722-M0	CD110-16V-220uF-M
C629	464-6D747-M0	CD110-16V-470uF-M
C110	464-6D747-M0	CD110-16V-470uF-M
C535	464-6D810-M0	CD110-16V-1000uF-M
C534	464-6D810-M0	CD110-16V-1000uF-M
C532	464-6F710-M0	CD110-35V-100uF-M
C103	464-6F747-M0	CD110-35V-470uF-M
C102	464-6F747-M0	CD110-35V-470uF-M
C302	464-6F810-M0	CD110-35V-1000uF-M
C138	464-6F810-M0	CD110-35V-1000uF-M
C321	464-6F810-M0	CD110-35V-1000uF-M
C531	464-6F810-M0	CD110-35V-1000uF-M
C215	464-6D547-M02	CD110-16V-4.7uF-M
C545	464-6D547-M02	CD110-16V-4.7uF-M
C544	464-6D547-M02	CD110-16V-4.7uF-M
C129	464-6D547-M02	CD110-16V-4.7uF-M
C232	464-6D547-M02	CD110-16V-4.7uF-M
C820	464-6D747-M02	CD110-16V-470uF-M
C634	464-6D647-M02	CD110-16V-47uF-M
C610	464-6D710-M02	CD110-16V-100uF-M
C549	464-6D710-M02	CD110-16V-100uF-M
C220	464-6D710-M02	CD110-16V-100uF-M
C117	464-6D710-M02	CD110-16V-100uF-M

SYMBOL	PART NO.	DESCRIPTION
C633	464-6D710-M02	CD110-16V-100uF-M
C219	464-6D710-M02	CD110-16V-100uF-M
C540	464-6D710-M02	CD110-16V-100uF-M
C546	464-6D710-M02	CD110-16V-100uF-M
C818	464-6D710-M02	CD110-16V-100uF-M
C810	464-6D710-M02	CD110-16V-100uF-M
C231	464-6D722-M02	CD110-16V-220uF-M
C205	464-6D733-M02	CD110-16V-330uF-M
C550	464-6D747-M02	CD110-16V-470uF-M
C602	464-6E610-M02	CD110-25V-10uF-M
C623	464-6E610-M02	CD110-25V-10uF-M
C625	464-6E610-M02	CD110-25V-10uF-M
C802	464-6E610-M02	CD110-25V-10uF-M
C626	464-6E610-M02	CD110-25V-10uF-M
C631	464-6E610-M02	CD110-25V-10uF-M
C630	464-6E610-M02	CD110-25V-10uF-M
C654	464-6E647-M02	CD110-25V-47uF-M
C365	464-6E710-M02	CD110-25V-100uF-M
C314	464-6E722-M02	CD110-25V-220uF-M
C120	464-6F610-M02	CD110-35V-10uF-M
C133	464-6F610-M02	CD110-35V-10uF-M
C121	464-6F610-M02	CD110-35V-10uF-M
C132	464-6F610-M02	CD110-35V-10uF-M
C130	464-6F610-M02	CD110-35V-10uF-M
C131	464-6F610-M02	CD110-35V-10uF-M
C310	464-6F710-M02	CD110-35V-100uF-M
C536	464-6F710-M02	CD110-35V-100uF-M
C640	464-60447-M02	CD110-50V-0.47uF-M
C204	464-60447-M02	CD110-50V-0.47uF-M
C224	464-60447-M02	CD110-50V-0.47uF-M
C601	464-60510-M02	CD110-50V-1uF-M
C213	464-60510-M02	CD110-50V-1uF-M
C111	464-60510-M02	CD110-50V-1uF-M
C113	464-60510-M02	CD110-50V-1uF-M
C620	464-60510-M02	CD110-50V-1uF-M
C616	464-60510-M02	CD110-50V-1uF-M
C613	464-60510-M02	CD110-50V-1uF-M
C624	464-60510-M02	CD110-50V-1uF-M
C801	464-60510-M02	CD110-50V-1uF-M
C128	464-60533-M02	CD110-50V-3.3uF-M

SYMBOL	PART NO.	DESCRIPTION
C305	464-60547-M02	CD110-50V-4.7uF-M
C635	464-60610-M02	CD110-50V-10uF-M
C645	464-60610-M02	CD110-50V-10uF-M
C612	464-60610-M02	CD110-50V-10uF-M
C614	464-60610-M02	CD110-50V-10uF-M
C615	464-60610-M02	CD110-50V-10uF-M
C617	464-60610-M02	CD110-50V-10uF-M
C619	464-60610-M02	CD110-50V-10uF-M
C621	464-60610-M02	CD110-50V-10uF-M
C221	464-60610-M02	CD110-50V-10uF-M
C541	464-60610-M02	CD110-50V-10uF-M
C307	464-60610-M02	CD110-50V-10uF-M
C320	464-60610-M02	CD110-50V-10uF-M
C366	464-60610-M02	CD110-50V-10uF-M
C229	464-60647-M02	CD110-50V-47uF-M
C101	464-60710-M02	CD110-50V-100uF-M
C542	464-60710-M02	CD110-50V-100uF-M
C330	464-62510-M02	CD288-160V-1uF-M
C208	464-60510-M02	CD110-50V-1uF-M
C209	464-60510-M02	CD110-50V-1uF-M
C210	464-60510-M02	CD110-50V-1uF-M
C211	464-60510-M02	CD110-50V-1uF-M
C652	464-60610-M0	CD110-50V-10uF-M
C515	464-YG710-M0	CD110LZ-63V-100uF-M
	464-30547-M0	CD11W-50V-4.7uF-M
CARBON RESISTOR		
R110	467-1CA22-H03	1/6W-2.2 Ω -J
R101	467-1CA22-H03	1/6W-2.2 Ω -J
R226	467-1C047-H03	1/6W-47 Ω -J
R648	467-1C047-H03	1/6W-47 Ω -J
R627	467-1C047-H03	1/6W-47 Ω -J
R633	467-1C047-H03	1/6W-47 Ω -J
R609	467-1C068-H03	1/6W-68 Ω -J
R622	467-1C075-H03	1/6W-75 Ω -J
R615	467-1C075-H03	1/6W-75 Ω -J
R619	467-1C075-H03	1/6W-75 Ω -J
R604	467-1C082-H03	1/6W-82 Ω -J
R601	467-1C082-H03	1/6W-82 Ω -J
R809	467-1C110-H03	1/6W-100 Ω -J
R217	467-1C110-H03	1/6W-100 Ω -J

SYMBOL	PART NO.	DESCRIPTION
R209	467-1C110-H03	1/6W-100 Ω -J
R211	467-1C110-H03	1/6W-100 Ω -J
R212	467-1C110-H03	1/6W-100 Ω -J
R613	467-1C110-H03	1/6W-100 Ω -J
R614	467-1C110-H03	1/6W-100 Ω -J
R616	467-1C110-H03	1/6W-100 Ω -J
R618	467-1C110-H03	1/6W-100 Ω -J
R617	467-1C110-H03	1/6W-100 Ω -J
R637	467-1C110-H03	1/6W-100 Ω -J
R118	467-1C110-H03	1/6W-100 Ω -J
R119	467-1C110-H03	1/6W-100 Ω -J
R220	467-1C110-H03	1/6W-100 Ω -J
R234	467-1C110-H03	1/6W-100 Ω -J
R235	467-1C110-H03	1/6W-100 Ω -J
R643	467-1C110-H03	1/6W-100 Ω -J
R640	467-1C110-H03	1/6W-100 Ω -J
R224	467-1C110-H03	1/6W-100 Ω -J
R340	467-1C110-H03	1/6W-100 Ω -J
R814	467-1C110-H03	1/6W-100 Ω -J
R642	467-1C112-H03	1/6W-120 Ω -J
R343	467-1C115-H03	1/6W-150 Ω -J
R342	467-1C115-H03	1/6W-150 Ω -J
R375	467-1C115-H03	1/6W-150 Ω -J
R641	467-1C120-H03	1/6W-200 Ω -J
R236	467-1C120-H03	1/6W-200 Ω -J
R812	467-1C122-H03	1/6W-220 Ω -J
R639	467-1C122-H03	1/6W-220 Ω -J
R222	467-1C122-H03	1/6W-220 Ω -J
R621	467-1C122-H03	1/6W-220 Ω -J
R530	467-1C122-H03	1/6W-220 Ω -J
R114	467-1C127-H03	1/6W-270 Ω -J
R116	467-1C127-H03	1/6W-270 Ω -J
R225	467-1C127-H03	1/6W-270 Ω -J
R649	467-1C127-H03	1/6W-270 Ω -J
R824	467-1C133-H03	1/6W-330 Ω -J
R832	467-1C133-H03	1/6W-330 Ω -J
R830	467-1C133-H03	1/6W-330 Ω -J
R214	467-1C133-H03	1/6W-330 Ω -J
R630	467-1C133-H03	1/6W-330 Ω -J
R202	467-1C133-H03	1/6W-330 Ω -J

SYMBOL	PART NO.	DESCRIPTION
R203	467-1C133-H03	1/6W-330 Ω -J
R205	467-1C133-H03	1/6W-330 Ω -J
R652	467-1C133-H03	1/6W-330 Ω -J
R644	467-1C133-H03	1/6W-330 Ω -J
R623	467-1C133-H03	1/6W-330 Ω -J
R229	467-1C133-H03	1/6W-330 Ω -J
R653	467-1C139-H03	1/6W-390 Ω -J
R815	467-1C147-H03	1/6W-470 Ω -J
R208	467-1C147-H03	1/6W-470 Ω -J
R369	467-1C147-H03	1/6W-470 Ω -J
R374	467-1C147-H03	1/6W-470 Ω -J
R635	467-1C147-H03	1/6W-470 Ω -J
R111	467-1C156-H03	1/6W-560 Ω -J
R624	467-1C156-H03	1/6W-560 Ω -J
R634	467-1C156-H03	1/6W-560 Ω -J
R331	467-1C156-H03	1/6W-560 Ω -J
R338	467-1C156-H03	1/6W-560 Ω -J
R337	467-1C156-H03	1/6W-560 Ω -J
R334	467-1C156-H03	1/6W-560 Ω -J
R807	467-1C168-H03	1/6W-680 Ω -J
R505	467-1C168-H03	1/6W-680 Ω -J
R645	467-1C182-H03	1/6W-820 Ω -J
R514	467-1DA56-H03	RT14-1/4W-5.6 Ω -J
R228	467-1C210-H03	1/6W-1K-J
R206	467-1C210-H03	1/6W-1K-J
R828	467-1C210-H03	1/6W-1K-J
R625	467-1C210-H03	1/6W-1K-J
R631	467-1C210-H03	1/6W-1K-J
R827	467-1C210-H03	1/6W-1K-J
R826	467-1C210-H03	1/6W-1K-J
R210	467-1C210-H03	1/6W-1K-J
R365	467-1C210-H03	1/6W-1K-J
R368	467-1C210-H03	1/6W-1K-J
R382	467-1C210-H03	1/6W-1K-J
R383	467-1C210-H03	1/6W-1K-J
R232	467-1C210-H03	1/6W-1K-J
R646	467-1C210-H03	1/6W-1K-J
R647	467-1C210-H03	1/6W-1K-J
R521	467-1C210-H03	1/6W-1K-J
R520	467-1C210-H03	1/6W-1K-J

SYMBOL	PART NO.	DESCRIPTION
R651	467-1C210-H03	1/6W-1K-J
R650	467-1C210-H03	1/6W-1K-J
R115	467-1C210-H03	1/6W-1K-J
R117	467-1C210-H03	1/6W-1K-J
R804	467-1C210-H03	1/6W-1K-J
R816	467-1C215-H03	1/6W-1.5K-J
R370	467-1C218-H03	1/6W-1.8K-J
R805	467-1C222-H03	1/6W-2.2K-J
R626	467-1C222-H03	1/6W-2.2K-J
R632	467-1C222-H03	1/6W-2.2K-J
R638	467-1C222-H03	1/6W-2.2K-J
R636	467-1C222-H03	1/6W-2.2K-J
R207	467-1C222-H03	1/6W-2.2K-J
R516	467-1C210-H03	1/6W-1K-J
R215	467-1C233-H03	1/6W-3.3K-J
R346	467-1C233-H03	1/6W-3.3K-J
R330	467-1C233-H03	1/6W-3.3K-J
R656	467-1C233-H03	1/6W-3.3K-J
R659	467-1C233-H03	1/6W-3.3K-J
R510	467-1C233-H03	1/6W-3.3K-J
R833	467-1C233-H03	1/6W-3.3K-J
R213	467-1C233-H03	1/6W-3.3K-J
R227	467-1C236-H03	1/6W-3.6K-J
R811	467-1C239-H03	1/6W-3.9K-J
R808	467-1C239-H03	1/6W-3.9K-J
R360	467-1C239-H03	1/6W-3.9K-J
R661	467-1C239-H03	1/6W-3.9K-J
R529	467-1C239-H03	1/6W-3.9K-J
R821	467-1C247-H03	1/6W-4.7K-J
R109	467-1C247-H03	1/6W-4.7K-J
R320	467-1C251-H03	1/6W-5.1K-J
R314	467-1C251-H03	1/6W-5.1K-J
R204	467-1C282-H03	1/6W-8.2K-J
R810	467-1C310-H03	1/6W-10K-J
R818	467-1C310-H03	1/6W-10K-J
R819	467-1C310-H03	1/6W-10K-J
R820	467-1C310-H03	1/6W-10K-J
R801	467-1C310-H03	1/6W-10K-J
R802	467-1C310-H03	1/6W-10K-J
R536	467-1C310-H03	1/6W-10K-J

SYMBOL	PART NO.	DESCRIPTION
R201	467-1C310-H03	1/6W-10K-J
R325	467-1C310-H03	1/6W-10K-J
R834	467-1C310-H03	1/6W-10K-J
R384	467-1C310-H03	1/6W-10K-J
R386	467-1C310-H03	1/6W-10K-J
R327	467-1C310-H03	1/6W-10K-J
R347	467-1C310-H03	1/6W-10K-J
R658	467-1C310-H03	1/6W-10K-J
R655	467-1C310-H03	1/6W-10K-J
R662	467-1C310-H03	1/6W-10K-J
R534	467-1C310-H03	1/6W-10K-J
R803	467-1C312-H03	1/6W-12K-J
R105	467-1C315-H03	1/6W-15K-J
R103	467-1C315-H03	1/6W-15K-J
R318	467-1C315-H03	1/6W-15K-J
R367	467-1C318-H03	1/6W-18K-J
R822	467-1C320-H03	1/6W-20K-J
R603	467-1C320-H03	1/6W-20K-J
R823	467-1C320-H03	1/6W-20K-J
R654	467-1C320-H03	1/6W-20K-J
R817	467-1C322-H03	1/6W-22K-J
R381	467-1C322-H03	1/6W-22K-J
R364	467-1C322-H03	1/6W-22K-J
R106	467-1C327-H03	1/6W-27K-J
R104	467-1C327-H03	1/6W-27K-J
R107	467-1C330-H03	1/6W-30K-J
R829	467-1C333-H03	1/6W-33K-J
R380	467-1C333-H03	1/6W-33K-J
R307	467-1C333-H03	1/6W-33K-J
R221	467-1C333-H03	1/6W-33K-J
R371	467-1C339-H03	1/6W-39K-J
R608	467-1C347-H03	1/6W-47K-J
R610	467-1C347-H03	1/6W-47K-J
R611	467-1C347-H03	1/6W-47K-J
R612	467-1C347-H03	1/6W-47K-J
R629	467-1C347-H03	1/6W-47K-J
R620	467-1C347-H03	1/6W-47K-J
R230	467-1C347-H03	1/6W-47K-J
R231	467-1C356-H03	1/6W-56K-J
R319	467-1C356-H03	1/6W-56K-J

SYMBOL	PART NO.	DESCRIPTION
R379	467-1C356-H03	1/6W-56K-J
R813	467-1C368-H03	1/6W-68K-J
R373	467-1C391-H03	1/6W-91K-J
R657	467-1C410-H03	1/6W-100K-J
R660	467-1C410-H03	1/6W-100K-J
R233	467-1C412-H03	1/6W-120K-J
R362	467-1C415-H03	1/6W-150K-J
R363	467-1C415-H03	1/6W-150K-J
R366	467-1C415-H03	1/6W-150K-J
R372	467-1C415-H03	1/6W-150K-J
R216	467-1C420-H03	1/6W-200K-J
R108	467-1C422-H03	1/6W-220K-J
R376	467-1C422-H03	1/6W-220K-J
R806	467-1C456-H03	1/6W-560K-J
R513	467-1C510-H03	1/6W-1M-J
R223	467-1C515-H03	1/6W-1.5M-J
R326	467-1D033-H03	RT14-1/4W-33 Ω -J
R311	467-1D210-H03	RT14-1/4W-1K-J
R512	467-1D222-H03	RT14-1/4W-2.2K-J
R528	467-1D227-H03	RT14-1/4W-2.7K-J
R336	467-1D227-H03	RT14-1/4W-2.7K-J
R507	467-1D233-H03	RT14-1/4W-3.3K-J
R310	467-1D268-H03	RT14-1/4W-6.8K-J
R309	467-1D310-H03	RT14-1/4W-10K-J
R523	467-1D322-H03	RT14-1/4W-22K-J
R328	467-1D324-H03	RT14-1/4W-24K-J
R321	467-1E327-H03	1/2W-27K-J
R335	467-1C220-H03	1/6W-2K-J
R385	467-1C382-H03	1/6W-82K-J
R344	467-1E012-H03	1/2W-12 Ω -J
IC		
D209	352-05740-00	uPC574
N502	352-06210-7Q	TLP621-GB(UL)
N102	352-13040-90	TA1304N
N801	352-24080-50	M24C08BN6
N603	352-40530-00	TC4053BP
N601	352-52797-20	M52797SP
N101	352-75820-10	AN7582
N301	352-78041-00	LA78041
N503	352-78050-00	KA7805

SYMBOL	PART NO.	DESCRIPTION
N201	352-88290-20	A8829CSNG4u60
N602	352-90450-50	TC90A45P
N501	352-96560-00	STR-G9656
AV SOCKET		
X601	364-92210-00	417
RELAY		
RY1	457-12003-9G	JQX-14FF-012-1HS
SAW FILTER		
Z201	458-07008-00	M1962M
CEMENT RESISTOR		
R377	467-50A56-HD	RX27-3-5-5.6 Ω -J
WIRE-ROUND RESISTOR		
R302	467-AF001-H0	RX21F-1W-1 Ω -JL
METAL RESISTOR		
R323	467-2D282-G03	1/4W-8.2K-G
R525	467-2D239-H0	1/4W-3.9K-J
R303	467-2D310-H0	1/4W-10K-J
R306	467-2D311-H0	1/4W-11K-J
R524	467-2D415-H0	1/4W-150K-J
R305	467-2EB82-H0	1/2W-0.82 Ω -JL
R532	467-2E136-H0	1/2W-360 Ω -JL
R533	467-2E182-H0	1/2W-820 Ω -JL
R361	467-2E333-H0	1/2W-33K-JL
R522	467-2F012-H0	1W-12 Ω -JL
R324	467-2F210-H0	1W-1K Ω -JL
R317	467-2F310-H0	1W-10k Ω -JL
R511	467-2F333-H0	1W-33k Ω -JL
R509	467-2F347-H0A	1W-47k Ω -J
R339	467-2F351-H0	1W-51k Ω -JL
R508	467-2F351-H0A	1W-51k Ω -J
R526	467-2F382-H0	1W-82k Ω -JL
R506	467-2GA01-H2	RY21-2W-0.1 Ω -JL
R341	467-2GA56-H0	2W-5.6 Ω -JL
R301	467-2G127-H0	2W-270 Ω -JL
R332	467-2G291-H0	2W-9.1k Ω -JL
R535	467-2G320-H0	2W-20K-JL
R527	467-2H115-H0D	3W-150 Ω -JL
R333	467-20239-HB	RYG2-5W-3.9K-J-A
MELTABLE RESISTOR		
R313	467-4FA24-H0	1W-2.4 Ω -JL

SYMBOL	PART NO.	DESCRIPTION
R519	467-4FB33-H0	1W-0.33 Ω -JL
R315	467-4F001-H0	1W-1 Ω -JL
R312	467-4F001-H0	1W-1 Ω -JL
R517	467-4F001-H0	1W-1 Ω -JL
R308	467-4F010-H0	1W-10 Ω -JL
R518	467-4GA22-H0	2W-2.2 Ω -JL
CARBON RESISTOR		
R502	467-8E510-H0A	1/2W-1M Ω -J
R515	467-8E582-H0A	1/2W-8.2M Ω -J
THERMISTOR		
R503	469-10023-00	96708 (9 Ω)
R501	469-40004-00	5D2-14LC
SWITCH TRANSFORMER		
T502	470-00285-00	SD4917B
	470-00285-00	SD4917B
POTENTIOMETER		
RP501	468-02101-00	WI02A-2-1KB
INDUCTANCE WITH COLOUR CODES		
L208	471-2B56K-003	SPT0305-R56K-5
L205	471-2B56K-003	SPT0305-R56K-5
L603	471-2010K-003	SPT0305-100K-5
L604	471-2010K-003	SPT0305-100K-5
L607	471-2010K-003	SPT0305-100K-5
L608	471-2010K-003	SPT0305-100K-5
L207	471-2068K-003	SPT0305-680K-5
L606	471-2110K-003	SPT0305-101K-5
L611	471-2110K-003	SPT0305-101K-5
L609	471-2110K-003	SPT0305-101K-5
L203	471-1056K-00	EL0606SK1-560K
L616	471-1110H-00	EL0606SKI-101J
L802	471-1110H-00	EL0606SKI-101J
L201	471-1110H-00	EL0606SKI-101J
L613	471-1110H-00	EL0606SKI-101J
L612	471-2012K-A0	SP0203-12uH-K
L614	471-2015K-A0	SP0203-15uH-K
L615	471-2027K-A0	SP0203-27uH-K
L202	471-2056H-60	LGA0307-56uH-J
L101	471-2056H-60	LGA0307-56uH-J
L801	471-2056H-60	LGA0307-56uH-J
L204	471-2056H-60	LGA0307-56uH-J

SYMBOL	PART NO.	DESCRIPTION
L206	471-2056H-60	LGA0307-56uH-J
L601	471-2056H-60	LGA0307-56uH-J
CERAMIC TRAP FILTER		
Z601	475-25451-00	XT4.5MB
CERAMIC FILTER		
Z202	475-15451-00	LT4.5MH
H-LINEARITY COIL		
L303	477-00048-00	TX520
POWER FILTER		
T500	477-20005-00	LF21061
T501	477-20031-00	LCL-21
FIXED INDUCTANCE		
L307	477-40057-00	LG101
L306	477-40073-00	TLN3197D
H-DRIVE TRANSFORMER		
T303	472-10001-00	XR0961
FBT		
T302	472-2B116-00	BSC29-3911N(UL)
OTHER		
TUNER	590-40713-00	TDQ-3B8G/134X
POWER CORD	491-752J0-02	UL
FUSE(J191)	569-17145-00	20T-1.5A/250V
FUSE(FU501)	569-18101-00	51S 5A/125V
DEGAUSSING COIL	477-13401-00	DX-87
SPEAKER	384-40908-J1	ST313-1B
SPEAKER	384-41908-S0	YDTG37-1B
CRT	335-34129-00U	A80LJF60X10(C)

CRT BOARD

SYMBOL	PART NO.	DESCRIPTION
	782-W2935-020A	CRT MAIN
DIODE		
D401	340-00001-00	1N4148
D402	340-00001-00	1N4148
D403	340-00001-00	1N4148
D404	340-00001-00	1N4148
D405	340-00001-00	1N4148
D407	340-00001-00	1N4148

SYMBOL	PART NO.	DESCRIPTION
D408	340-00001-00	1N4148
D409	340-00001-00	1N4148
D410	340-00001-00	1N4148
TRANSISTOR		
V411	343-05620-10	2SA562TM-Y
V415	343-10150-10	2SA1015Y
V401	343-18150-11	2SC1815-Y
V402	343-18150-11	2SC1815-Y
V404	343-18150-11	2SC1815-Y
V406	343-18150-11	2SC1815-Y
V408	343-18150-11	2SC1815-Y
V409	343-18150-11	2SC1815-Y
V410	343-18150-11	2SC1815-Y
V413	343-18150-11	2SC1815-Y
V414	343-18150-11	2SC1815-Y
V416	343-19640-30	2SA1964E
V403	343-26880-60	2SC2688M
V405	343-26880-60	2SC2688M
V407	343-26880-60	2SC2688M
V417	343-52480-30	2SC5248E
CRT SOCKET		
X404	364-58210-00	GZS10-2-102G
CERAMIC CAPACITOR		
C446	459-2082H-10	CC1-08-63V-82pF-J
C447	459-2082H-10	CC1-08-63V-82pF-J
C448	459-2082H-10	CC1-08-63V-82pF-J
C419	459-2110H-10D	CC1-08-CH-63V-101J
C420	459-2110H-10D	CC1-08-CH-63V-101J
C403	459-2127H-90	CC1-08-SL-63V-271J
C405	459-2127H-90	CC1-08-SL-63V-271J
C406	459-2127H-90	CC1-08-SL-63V-271J
C409	459-2147H-90	CC1-12-SL-63V-471J
C410	459-2147H-90	CC1-12-SL-63V-471J
C411	459-2147H-90	CC1-12-SL-63V-471J
C414	459-2156H-90	CC1-12-SL-63V-561J
C417	459-2210K-00	CT1-06-2B4-63V-102K
C421	459-2247R-00	CT1-08-2E4-63V-472Z
C422	459-2247R-00	CT1-08-2E4-63V-472Z
C404	459-2310R-00	CT1-08-2F4-63V-103Z
C412	459-2310R-00	CT1-08-2F4-63V-103Z

SYMBOL	PART NO.	DESCRIPTION
C426	459-5056H-90	CC45SL2H560JYJ
C424	459-8222K-00	DE1005B222K2K
THIN-FILM CAPACITOR		
C402	462-00282-H0	CL11-100V-8200pF-J
ELECTROLYTIC CAPACITOR		
C423	464-6D647-M0	CD110-16V-47uF-M
C425	464-6D647-M0	CD110-16V-47uF-M
C415	464-6D722-M0	CD110-16V-220uF-M
C401	464-6E610-M0	CD110-25V-10uF-M
C407	464-6E710-M0	CD110-25V-100uF-M
C418	464-62610-M0	CD288-160V-10uF-M
C427	464-62610-M0	CD288-160V-10uF-M
C416	464-65633-M0	CD288-250V-33uF-M
METAL RESISTOR		
R444	467-2E133-H0	1/2W-330 Ω -JL
R443	467-2E010-H0	1/2W-10 Ω -JL
R401	467-2E047-H0	1/2W-47 Ω -JL
R458	467-2F122-H0	1W-220 Ω -JL
R432	467-2G312-H0	2W-12k Ω -JL
R434	467-2G312-H0	2W-12k Ω -JL
R437	467-2G312-H0	2W-12k Ω -JL
CARBON RESISTOR		
R427	467-1C224-H0	1/6W-2.4K-J
R429	467-1C022-H0	1/6W-22 Ω -J
R428	467-1C047-H0	1/6W-47 Ω -J
R418	467-1C056-H0	1/6W-56 Ω -J
R419	467-1C056-H0	1/6W-56 Ω -J
R420	467-1C056-H0	1/6W-56 Ω -J
R445	467-1C082-H0	1/6W-82 Ω -J
R446	467-1C082-H0	1/6W-82 Ω -J
R406	467-1C127-H0	1/6W-270 Ω -J
R407	467-1C127-H0	1/6W-270 Ω -J
R408	467-1C127-H0	1/6W-270 Ω -J
R415	467-1C127-H0	1/6W-270 Ω -J
R422	467-1C147-H0	1/6W-470 Ω -J
R412	467-1C156-H0	1/6W-560 Ω -J
R413	467-1C156-H0	1/6W-560 Ω -J
R414	467-1C156-H0	1/6W-560 Ω -J
R423	467-1C168-H0	1/6W-680 Ω -J
R424	467-1C168-H0	1/6W-680 Ω -J

SYMBOL	PART NO.	DESCRIPTION
R425	467-1C168-H0	1/6W-680 Ω -J
R416	467-1C210-H0	1/6W-1K-J
R453	467-1C210-H0	1/6W-1K-J
R404	467-1C212-H0	1/6W-1.2K-J
R447	467-1C212-H0	1/6W-1.2K-J
R452	467-1C212-H0	1/6W-1.2K-J
R448	467-1C215-H0	1/6W-1.5K-J
R451	467-1C215-H0	1/6W-1.5K-J
R402	467-1C222-H0	1/6W-2.2K-J
R441	467-1C222-H0	1/6W-2.2K-J
R431	467-1C239-H0	1/6W-3.9K-J
R438	467-1C239-H0	1/6W-3.9K-J
R403	467-1C247-H0	1/6W-4.7K-J
R430	467-1C310-H0	1/6W-10K-J
R409	467-1C322-H0	1/6W-22K-J
R421	467-1C327-H0	1/6W-27K-J
R426	467-1C333-H0	1/6W-33K-J
R439	467-1C339-H0	1/6W-39K-J
R440	467-1C356-H0	1/6W-56K-J
R449	467-1C368-H0	1/6W-68K-J
R450	467-1C368-H0	1/6W-68K-J
R454	467-1DA27-H0	RT14-1/4W-2.7 Ω -J
R457	467-1DA27-H0	RT14-1/4W-2.7 Ω -J
R405	467-1D168-H0	RT14-1/4W-680 Ω -J
R455	467-1E047-H0	1/2W-47 Ω -J
R456	467-1E047-H0	1/2W-47 Ω -J
R417	467-1E147-H0	1/2W-470 Ω -J
MELTABLE RESISTOR		
R442	467-4FA15-H0	1W-1.5 Ω -JL
CARBON RESISTOR		
R433	467-8E227-H1A	1/2W-2.7K Ω -J
R435	467-8E227-H1A	1/2W-2.7K Ω -J
R436	467-8E227-H1A	1/2W-2.7K Ω -J
INDUCTANCE WITH COLOUR CODES		
L401	471-1056H-00	EL0606SKI-560J
L402	471-2110K-00	SPT0305-101K-5

STEREO BOARD

SYMBOL	PART NO.	DESCRIPTION
	782-Q2735-310A	STEREO BOARD
TRANSISTOR		
VS01	343-18150-104	2SC1815-Y
VS02	343-18150-104	2SC1815-Y
CERAMIC CAPACITOR		
CS04	459-2410R-00	DD308-63F104Z50
CS06	459-2410R-00	DD308-63F104Z50
CS10	459-2410R-00	DD308-63F104Z50
CS21	459-2410R-00	DD308-63F104Z50
CS12	459-5210K-00	RQC07B102K-H46CA
THIN-FILM CAPACITOR		
CS05	462-B0322-H02	CL21X-50V-0.022uF-J
CS07	462-B0333-H02	CL21X-50V-0.033uF
CS11	462-B0422-H02	CL21X-50V-0.22uF-J
ELECTROLYTIC CAPACITOR		
CS19	464-6D710-M0	CD110-16V-100uF-M
CS14	464-6E547-M0	CD110-25V-4.7uF-M
CS02	464-60433-M0	CD110-50V-0.33uF-M
CS09	464-60433-M0	CD110-50V-0.33uF-M
CS08	464-60522-M0	CD110-50V-2.2uF-M
CS15	464-60522-M0	CD110-50V-2.2uF-M
CS16	464-60522-M0	CD110-50V-2.2uF-M
CS17	464-60522-M0	CD110-50V-2.2uF-M
CS18	464-60522-M0	CD110-50V-2.2uF-M
CS20	464-60522-M0	CD110-50V-2.2uF-M
CS03	464-60533-M0	CD110-50V-3.3uF-M
CS01	464-60610-M0	CD110-50V-10uF-M
CARBON RESISTOR		
RS06	467-1C110-H03	1/6W-100 Ω -J
RS07	467-1C110-H03	1/6W-100 Ω -J
RS04	467-1C115-H03	1/6W-150 Ω -J
RS09	467-1C115-H03	1/6W-150 Ω -J
RS05	467-1C168-H03	1/6W-680 Ω -J
RS10	467-1C168-H03	1/6W-680 Ω -J
RS03	467-1C210-H03	1/6W-1K-J
RS08	467-1C210-H03	1/6W-1K-J
RS01	467-1C233-H03	1/6W-3.3K-J
RS02	467-1C418-H03	1/6W-180K-J

SYMBOL	PART NO.	DESCRIPTION
INDUCTANCE WITH COLOUR CODES		
LS01	471-2068K-103	LGA0410-68uH-K
SMD IC		
NS01	353-58320-50	ICAN5832SA

SIDE AV BOARD

SYMBOL	PART NO.	DESCRIPTION
	782-Q3280-2900	SIDE AV PCB
AV SOCKET		
XAA1	364-93202-00	AV306-2
CERAMIC CAPACITOR		
CAA1	459-2210K-00	CT1-06-2B4-63V-102K
CAA2	459-2210K-00	CT1-06-2B4-63V-102K
CARBON RESISTOR		
RAA1	467-1C075-H0	1/6W-75 Ω -J
RAA2	467-1C347-H0	1/6W-47K-J
RAA3	467-1C347-H0	1/6W-47K-J
INDUCTANCE WITH COLOUR CODES		
LAA1	471-2001K-00	SPT0305-1R0K-5
LAA2	471-2001K-00	SPT0305-1R0K-5

EXPLODED VIEW

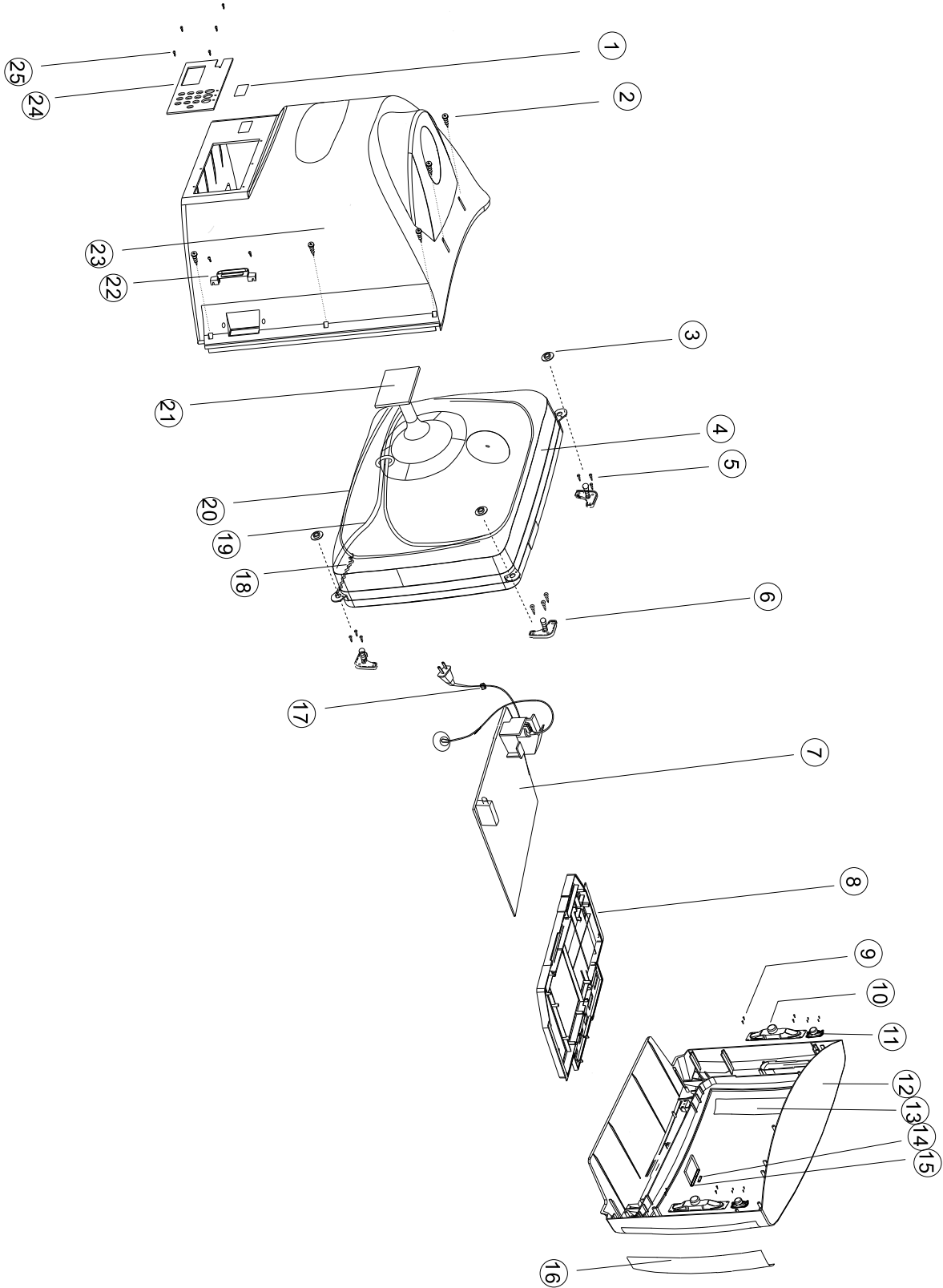

PARTS LIST

NO.	Description	Part number
1	LABEL	880-10230-002
2	SCREW	851-24018-14
3	COMPONENT NUT	648-30003-00
4	CRT	335-34129-00U
5	SCREW	851-24020-11
6	CRT WASHIER	868-20369-00
7	MAIN BOARD ASSEMBLY	667-Q3280-01A
8	MAIN FRAME	863-60094-U01
9	SCREW	851-53008-31
10	SPEAKER	384-40908-J1
11	SPEAKER (HIGHT)	384-41908-S0
12	FRONT CABINET ASSEMBLY	611-30346-J01
13	LEFT SPEAKER GRILLE	864-10067-08
14	LOGO	880-10413-01
15	DRAWER BUTTON ASSEMBLY	615-40051-00
16	RIGHT SPEAKER GRILLE	864-10068-08
17	POWER CORD CLAMPER	862-20028-00
18	BRAIDED PULLING SPRING	838-10012-00
19	DEGAUSSING COIL	477-13401-00
20	BRAIDED PULLING	123-30001-04
21	CRT BOARD ASSEMBLY	667-Q2735-02
22	SIDE AV BOARD ASSEMBLY	667-Q3280-29
23	BACK CABINET	780-10529-J00
24	REAR PANEL ASSEMBLY	535-Q3280-01
25	SCREW	851-24018-14